

DuraVision G5

Fully automatic serial testing: quick and precise

0.3-3000 kgf

Brinell

Vickers

Rockwell

Knoop

Plastic testing

Carbon testing

HBD, HVD

EMCO·TEST

Hardness testing for every application.

Test load range from 0.3 kgf to 3,000 kgf.

LOAD RANGE



HARDNESS TESTING MACHINE

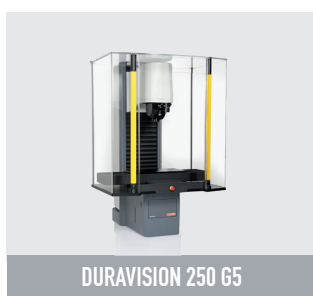

DURAVISION 250 G5

TEST METHODS



Brinell according to ISO 6506, ASTM E10

1/1	1/2.5	1/5	1/10
1/30	2.5/6.25	2.5/15.6	2.5/31.25
2.5/62.5	2.5/187.5	5/25	5/62.5
5/125	5/250	10/100	10/250
HBT (not standardised)			



Vickers according to ISO 6507, ASTM E384, E92

HV 0.3	HV 0.5	HV 1	HV 2	HV 2.5
HV 3	HV 5	HV 10	HV 20	HV 30
HV 50	HV 60	HV 100	HV 120	HV 125
HV 150	HVT (not standardised)			



Rockwell according to ISO 6508, ASTM E18

HRA - HRZ	HR15-N/T/W/X/Y
HR30-N/T/W/X/Y	HR45-N/T/W/X/Y



Knoop according to ISO 4545, ASTM E384, E92

HK 0.3	HK 0.5	HK 1	HK 2
--------	--------	------	------



Carbon testing According to DIN 51917

2.5/7	5/7	5/15	5/20	5/40
5/60	5/100	5/150	10/20	10/40
10/60	10/100	10/150		



Plastic testing according to EN ISO 2039

49.03 N	132.9 N	357.9 N	961 N
---------	---------	---------	-------

LOAD RANGE



HARDNESS TESTING MACHINE

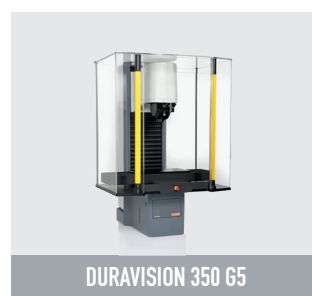

DURAVISION 350 G5

TEST METHODS



Brinell according to ISO 6506, ASTM E10

1/5	1/10	1/30	2.5/6.25
2.5/15.6	2.5/31.25	2.5/62.5	2.5/187.5
5/25	5/62.5	5/125	5/250
5/750	10/100	10/250	10/500
10/1000	10/1500	10/3000	
HBT (not standardised)			



Vickers according to ISO 6507, ASTM E384

HV 3	HV 5	HV 10	HV 20	HV 30
HV 50	HV 60	HV 100	HV 120	HV 125
HV 150	HVT (not standardised)			



Rockwell according to ISO 6508, ASTM E18

HRA - HRZ	HR15-N/T/W/X/Y
HR30-N/T/W/X/Y	HR45-N/T/W/X/Y



Carbon testing according to DIN 51917

2.5/7	5/7	5/15	5/20	5/40
5/60	5/100	5/150	10/20	10/40
10/60	10/100	10/150		

DuraVision 250 G5 and 350 G5.

Fully automated hardness testing for serial testing.

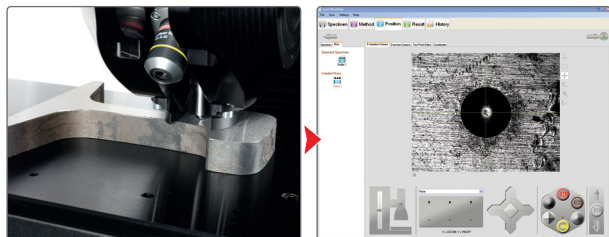

Reliably to the correct test result

Evaluation of the test indents is performed in the DuraVision G5 series with fully automatic brightness control and fast autofocus. The test load is applied using the proven concept of closed-loop control – the force is thereby continuously and precisely monitored by electronic force measuring sensors. Motorised cross slides position the test points with a high degree of repeatability and positioning accuracy, without any operator influence.

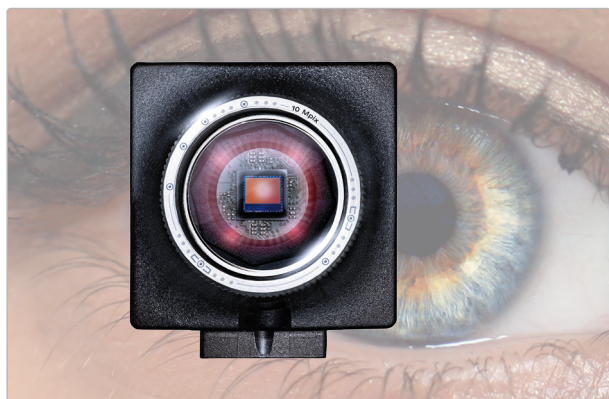

Broad spectrum of applications

The DuraVision G5 series offers a uniquely broad standard load range from 0.3 kgf to 3,000 kgf, thereby fulfilling the prerequisites for numerous different test methods. Furthermore, intelligent use of the high-resolution 12-megapixel camera allows a 3 step zoom without having to accept any loss in image quality due to interpolation. This innovative solution allows a wide range of applications to be covered with a small number of lenses. In order to make full use of this potential, the DuraVision G5 uses only lenses that offer maximum optical resolution. The 7 positions of the star turret also spare you from changing tools.

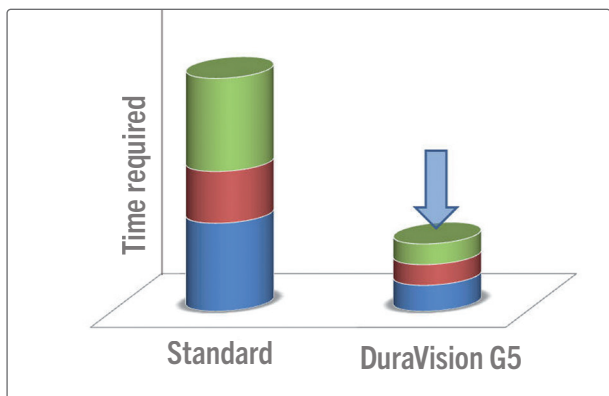

Time savings thanks to fast test cycles

The DuraVision G5 Automatic helps to save time, both in serial testing and in the case of alternating test requirements. Thanks to the new, patented rapid traverse, the height of the nose cone can be adjusted at up to 25 mm/s. Combined with intuitive operation and use of the template function, this enables quick configuration. The high degree of automation of the DuraVision G5 Automatic reduces the active operating time involved in serial testing many times over. The xChange interface included as standard allows the automatic import and export of test parameters and test results and speeds up the test cycle.

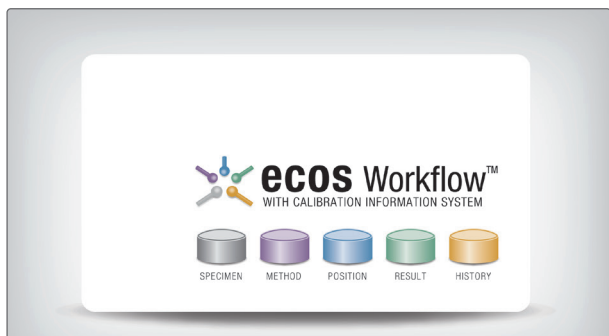

Intuitive software with calibration assistant

The **ecos** Workflow software package from EMCO-TEST provides an efficient, intelligent solution for all conventional hardness testing tasks. The user is guided step-by-step through the measuring process all the way to data backup. The intuitive user interface shortens the familiarisation time and reduces operating errors. A special feature of **ecos** Workflow is the integrated calibration assistant that monitors all calibrated methods and greatly simplifies the inspection of the hardness tester required by standards. The assistant indicates when periodic and indirect verifications in compliance with ISO and ASTM standards are due, it guides the user through the inspection process and supports documentation compliant with standards.

The DuraVision G5 Automatic.

Automation with the utmost precision.



CE protective housing

Maximum protection with highest levels of user-friendliness – together with the CE protective housing, the DuraVision G5 meets international CE requirements. The light barrier system means that no safety door needs to be opened in future in order to access the machine's testing area. User-friendliness is therefore increased without compromising safety. In countries where the CE label applies, the machine may only be supplied with the protective housing. For the purposes of automation, the DuraVision G5 is also available outside these countries without a protective housing, in which case the machine is supplied without a CE label.

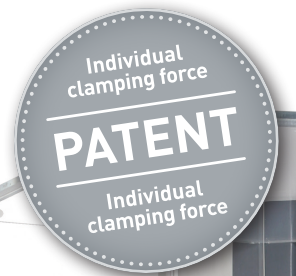

Intuitive operation

The hardness tester is controlled via the software **ecos** Workflow on an external PC.

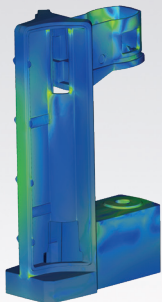
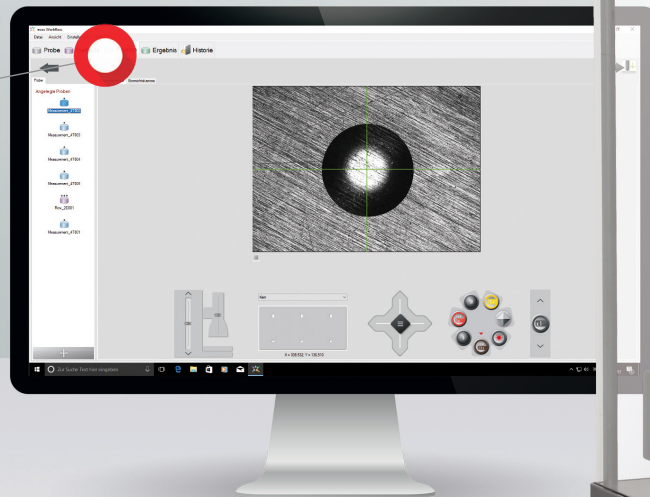

Material and technology

Whether subjected to a 0.3 kgf or 3,000 kgf test load, the rigid cast iron stand guarantees absolute test stability for the entire range of loads. By using precious components and materials we are also able to comply with North American safety standards (control unit 'UL-listed' for the highest standards of fire resistance for plastic covers).

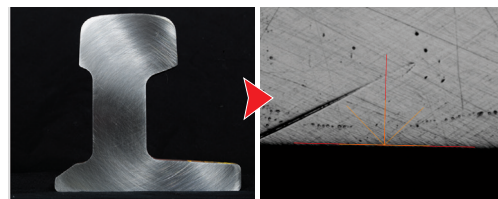

Overview camera

Evaluation camera

Overview camera (optional)

With the help of a “macro lens”, the 12Mpix overview colour camera generates a large live image of the sample and thus facilitates the setting of several test points and complicated gradient series - in combination with the evaluation lenses an unbeatable tool!



Slim nose cone with star-shaped turret

The nose cone of the DuraVision G5 can be configured either with a 2-fold star-shaped turret (standard) or with a 7-fold star-shaped turret (optional). The slim nose cone also makes it easy to test complex components.

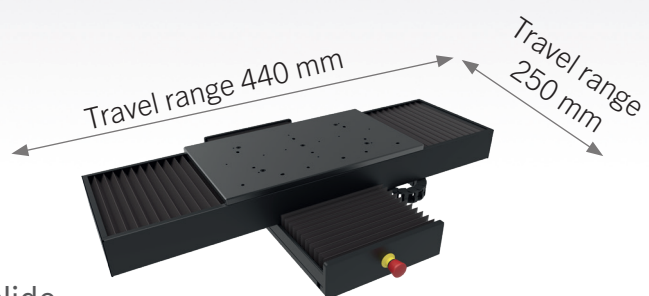

Motorised cross slide

The large travel ranges of the cross slide enable optimum, fully automatic hardness testing. The high resolution ensures a high degree of repeatability and positioning accuracy.

As simple as possible.

ecos Workflow Pro

The pioneering hardness testing software

ecos Workflow technology shows the way ahead. Simple operation of even the most complex automation tasks is becoming increasingly important in the realm of hardness testing. The software takes over the task of directing the increasingly broad range of testing requirements and guarantees simple test object administration and lasting data security. The large proportion of software in the testing equipment allows **ecos** Workflow to make a decisive contribution to the performance capacity and quality of the overall product.

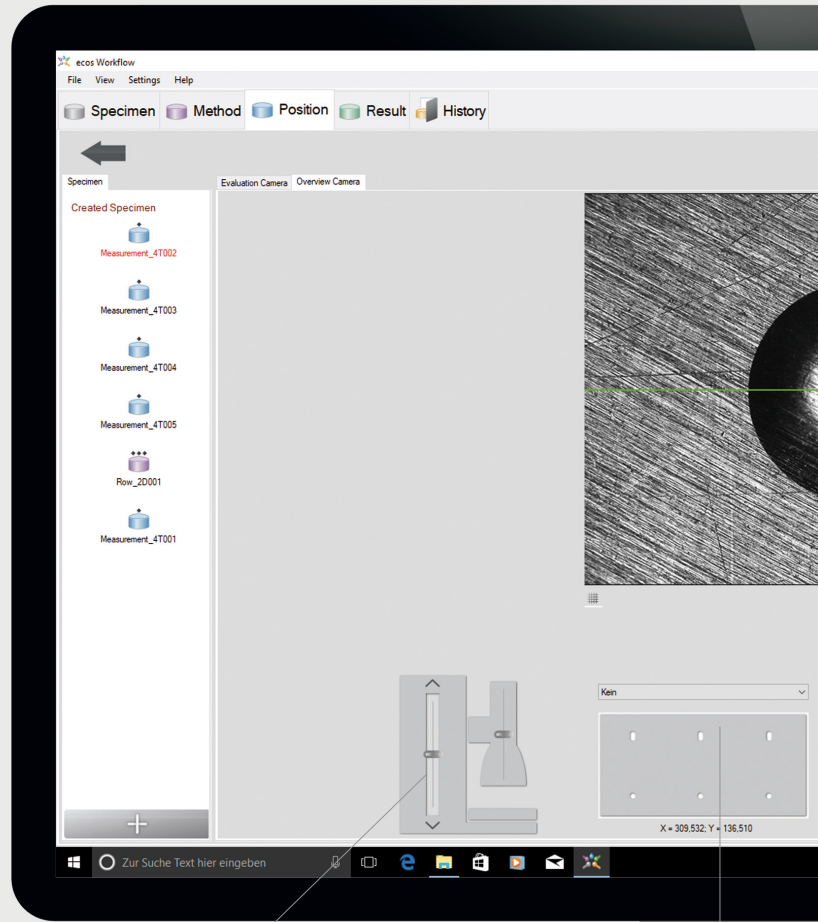

The workflow in five steps

Specimen, method, position, result and history are the five steps provided by the intuitive **ecos** Workflow operating software.

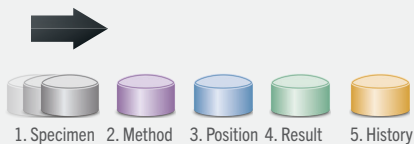

Z-axis control with autofocus

Specimen magazines

are shown clearly on the test table. One click on the image moves the machine to the desired position.

1 Specimen

Select the required test type. The available options are single measurement, serial measurement, CHD, SHD, and NHD processes.

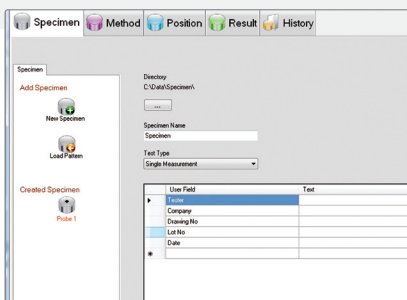

2 Method

Select the test procedure, lens, test method, zoom level and, if applicable, conversions, limit and geometric correction according to standard as well.

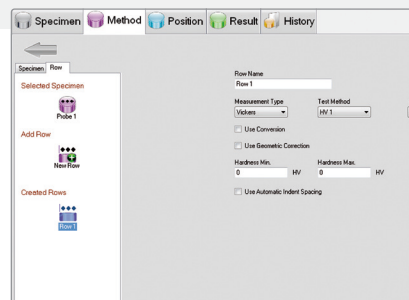

3 Position

Position your test points or progression rows on the workpiece. This is child's play with the tools provided. Then start the test.

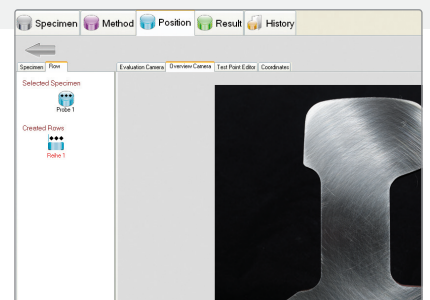

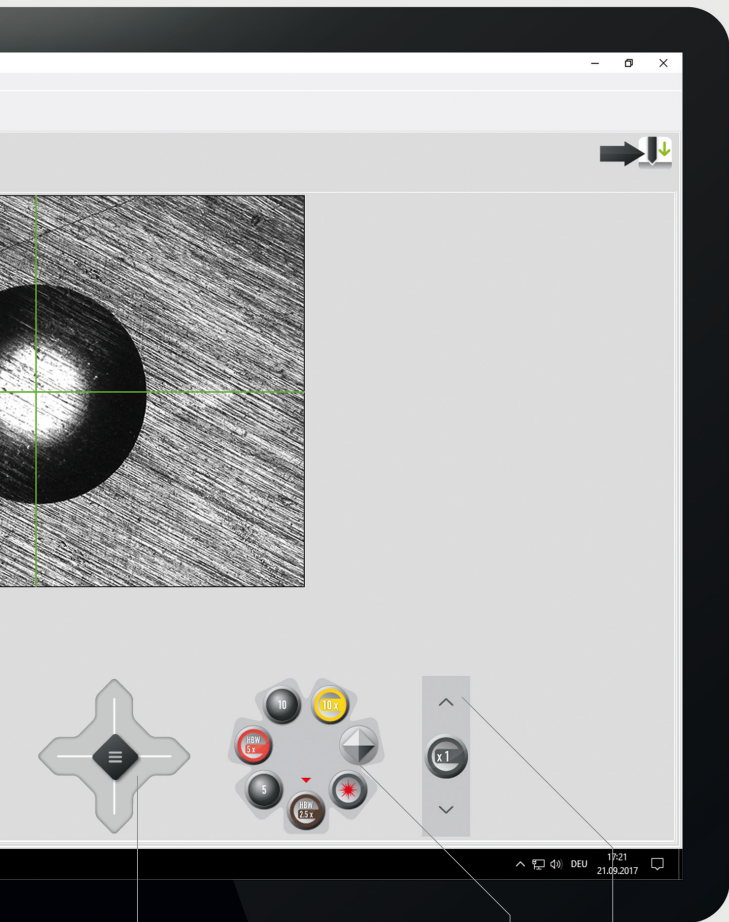

Symbolic image

XY axis controller
for positioning

4x zoom
Indication of the current zoom level

Star turret
with fitting info



Single measurement

This function allows individual test points to be defined as desired. The measurement can be started directly from the surface mask or the overview camera.



Serial measurement

One or more test series can be measured with position coordinates. The measurement can be started directly from the surface mask or the overview mask.



CHD, NHD, SHD measurement



One or more test series for standard-compliant CHD, NHD or SHD evaluation of specimens. The measurement can be started directly from the surface mask or the overview mask. For NHD measurements, additional core hardness points can be defined separately.



Jominy measurement (optional)

One or more test series can be measured with position coordinates. The measurement can be started directly from the surface mask or the overview mask.



Ready for



4 Result

The result is shown clearly and is available for further use. The measurement can also be repeated automatically or manually if required.

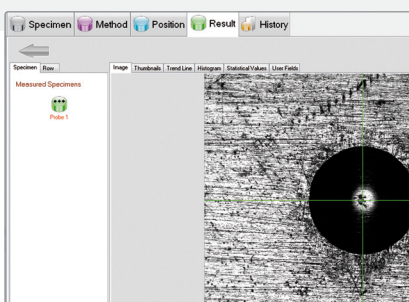

5 History

All results are stored permanently with a clear structure. You have the option to archive the data in your network and other systems or to create a report via a connected printer.

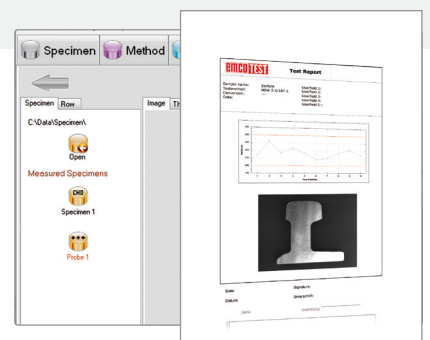
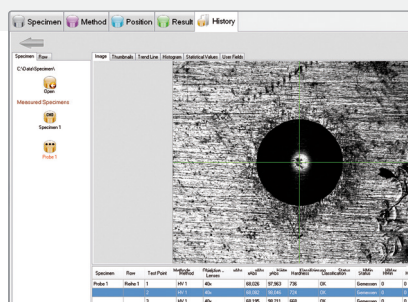

Important functions.

ecos Workflow Pro

The calibration assistant of **ecos** Workflow

The calibration assistant, integrated into the test software as standard, supports you in the inspection of all the calibrated methods of your hardness tester required by the standards. The software notifies you of upcoming inspections, guides you through the test cycle and supports appropriate documentation.

Further details can be found at: www.emcotest.com/ecosworkflow



Guide

Guides you through the inspection procedure



Information

Informs you of upcoming inspections



Documentation

Supports you in the documentation of the tests



Status

Informs you of the current status of the calibrated methods

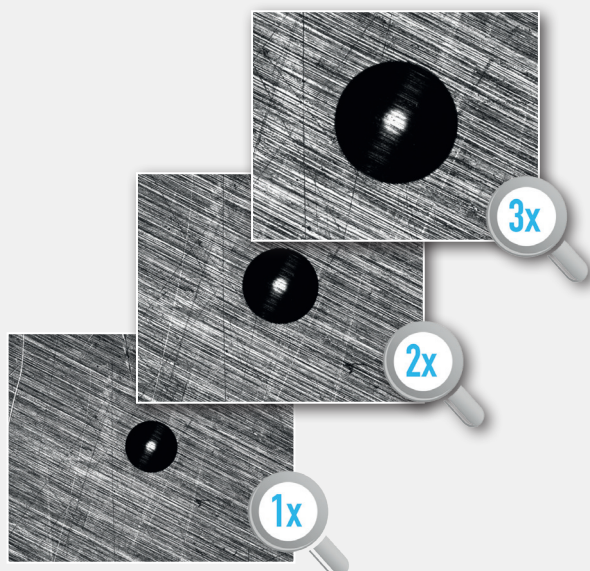

One lens – three magnifications

Intelligent interaction between the optical system and the software with 3-step zoom has made it possible to triple the magnification spectrum provided by the lens - while maintaining the same high standard of image quality. The unique 3-step zoom is a standard feature of the entire DuraVision G5 series, from basic through to high-end. This saves using additional lenses and thus reduces expenditure.

Simple management of user rights

The **ecos** Workflow operating software offers the possibility of selectively and individually controlling user rights by means of user levels. Any number of user levels with different rights can be created and changed at any time. All available rights can be very easily assigned to the desired user level with the help of a rights editor. The users are then assigned to the user level that can, if necessary, be additionally protected by means of a password. This ensures that only authorised users can perform a measurement with the required test method or can change machine settings.

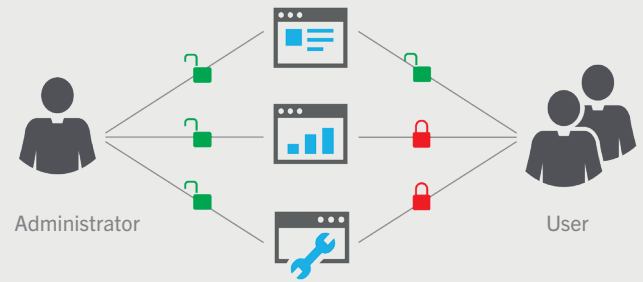

Collision detection system

All of our DuraLine machines are equipped with collision detection system as a standard feature. This system has been developed to ensure your safety and the functionality of your machine. It detects potential collisions to prevent damage to your machine. With this advanced technology, we minimize the risk of unexpected damage that could lead to significant repair costs or downtime.



Time saving pattern mode

Specimen that have already been measured are used as a guideline containing certain elements and basic settings for new specimen. The settings from the basic guideline are automatically used for new specimen. Guidelines are automatically generated for each measurement and archived specimen. Operators are recommended to use guideline settings when testing a series of identical parts, or when frequently testing parts that always conform to certain parameters, tolerance levels, test methods etc., or continually exhibit the same pattern of test results, but have varying descriptions. Conduct complex testing tasks with very few clicks.

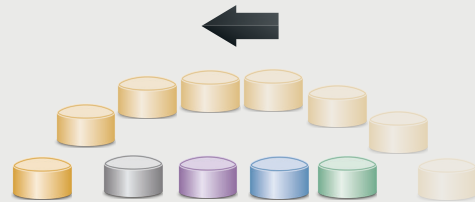

Specimens already measured can be used as templates for new measurements.

Variable clamping force

Thanks to the patented design of the Z-axis, the optimum force for clamping can be set as required in the software, depending on the specimen size and material. Even complex specimens can thus be reliably clamped by selecting a correspondingly higher clamping force. Marks on soft materials can be avoided by selecting a correspondingly lower clamping force.



Serial testing with the DuraVision G5.

Quick and easy testing of several work pieces.

Easy generation of test series

The test point editor allows test points to be easily set up in a grid. It is also possible to set up each individual test point by entering coordinates. An even more elegant solution for serial measurement is provided by line and polygon line tools. Test series can be automatically adapted to suit work piece contours. Compliance with standard defined test distances is also enabled by an integrated tool (i.e. point distance = 3 x diagonal).

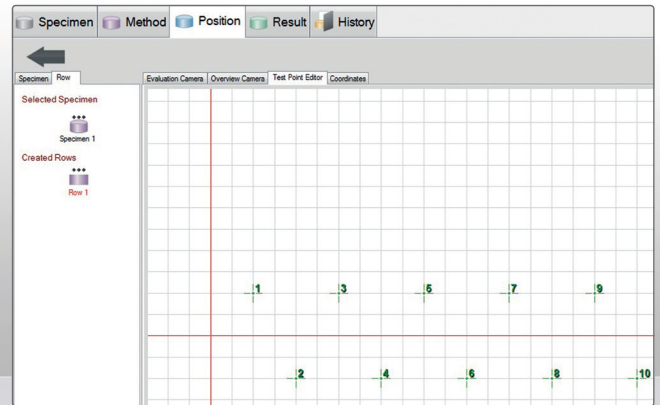

Positioning using a fixed reference point

Several test points or rows can be fixed very simply to a defined reference point and saved as a template. Later, this template can be easily placed over the new work piece and exactly positioned by rotation over the reference point.

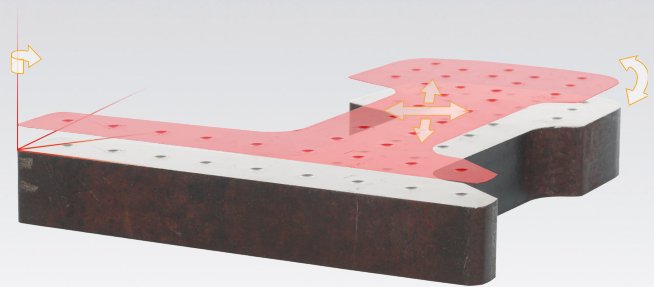

Testing of identical parts

If several work pieces with the same test requirements are placed and tested on the cross slide, the DuraVision is able to show the full range of its skills. All test parameters are taken from the existing template and transferred to the new work piece.



Work pieces with different heights

Even simultaneous serial testing of multiple specimens with different heights presents no problem at all for the DuraVision G5, whether with or without nose cone.

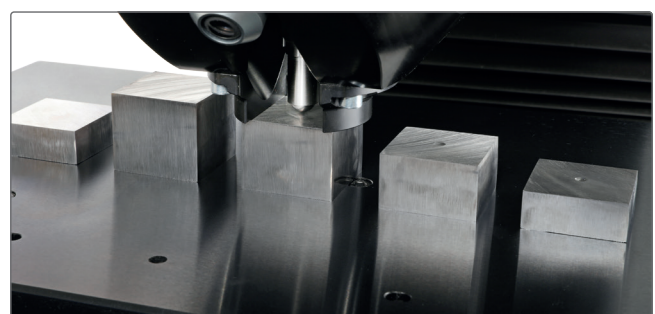

ecos PANORAMA

creates a panoramic view of your sample by taking photographs of the surface using the high precision evaluation lens and camera. The single photos are then stitched together to create an high resolution overview picture. Place test points, rows and lines directly by using this picture. The live image of the evaluation lens is shown as an overlay directly in the “off line” picture to allow high precision placement. Furthermore, this also ensures that the specimen is still in place.

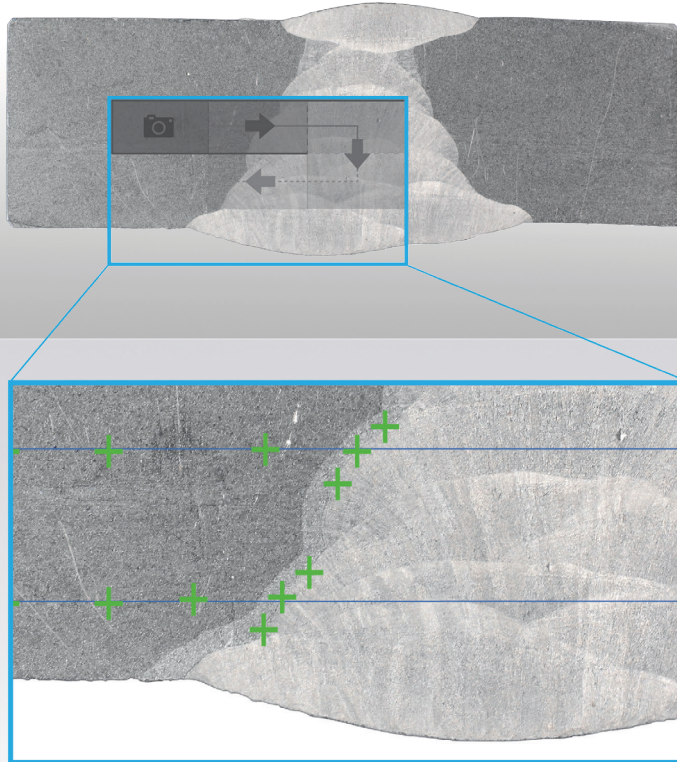

ecos AUTOROW

The optional **ecos** AUTOROW module allows row start points pre-positioned in the overview camera to be placed automatically at the specimen edge. In this process, the specimen edge is detected automatically and precisely in the measuring camera image, the row is shifted according to its alignment and then aligned at right angles to the specimen edge.

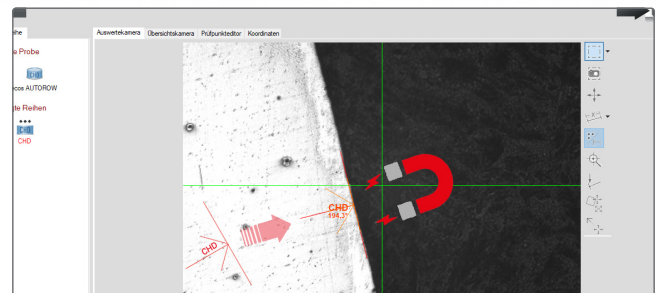

ecos LINEplus – your extensive toolbox

ecos LINEplus contains tools that help you place test points and rows precisely according to dimension specifications.

The reference line functions for length and angle allow you to quickly and easily define the position of row starting points or test points on the workpiece. They can also measure lengths and angles on the workpiece. All starting points and end points have a snap function, which allows multiple reference lines to be concatenated. Polylines and reference lines can always be edited at a later time and they can also be aligned on the component subsequently. This makes the efficient use of templates (samples) possible.

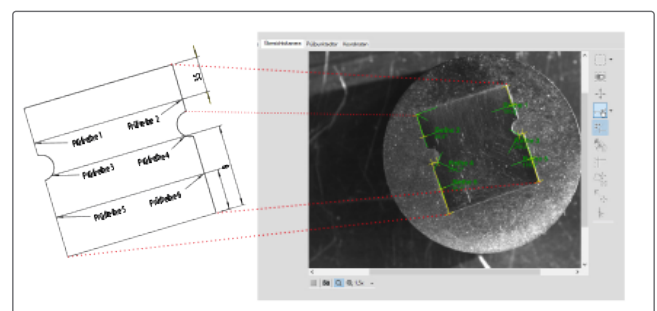

Modern data management with ecos Workflow.

Simple and safe handling of data.



Efficient data management

The DuraScan G5 models are equipped with industrial PLCs, making them pioneers in Industry 4.0, and optimized for intelligent manufacturing environments.

In addition to directly generating and securing test results, data can be individually exported in various formats such as .pdf, .xls, .csv, or .xml using the Export Editor. Integration with Q-DAS systems via .dfq file is also possible. Measurement results can be automatically exported to the internal network of ERP and quality systems such as SAP, MES, LIMS. Internet-based remote maintenance and an integrated calibration assistant make these machines future-proof.

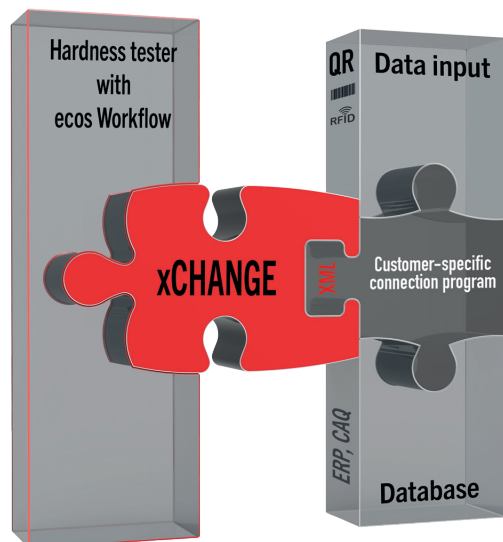

ecos Workflow xCHANGE

The **ecos** xChange interface is included as standard equipment in all DuraScan and Duravision hardness testing devices.

With this interface, every hardness tester can be integrated into production lines and communicate with custom software. The use of XML-based data makes it easy and structured to handle.



Create individual test reports

All models offer as standard the possibility of direct printing. This function allows a test report to be created using an inter-
faced printer. Furthermore, the form generator allows individual reports to be designed for documenting the test results.

Integration of your company logo into the test report

Individual fields for specimen designation and test parameters

Further free definable fields

Bar diagram, statistics, trend diagram, etc.

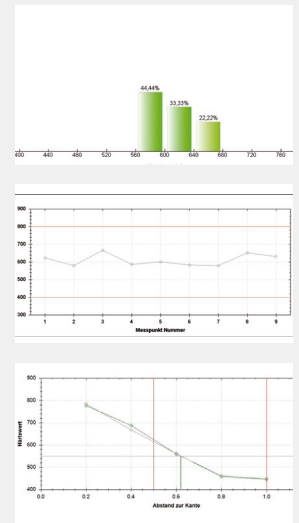

ecos CAPTURE generates pictures of your sample to be used in reports or to be stored separately. Choose if the picture should contain test points, row start points and reference points. With the **ecos LINEplus** add-on module, you can easily and accurately place test points by using helplines. The helplines, as well as the measurement results, can also be displayed in the image.

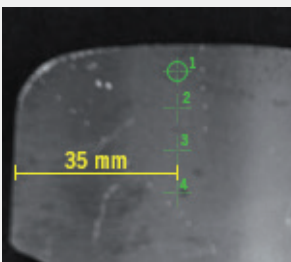

Date: _____ Datum: _____

Signature: _____ Unterschrift: _____

DSINW: _____ Unterschrift: _____

Measured value tables, statistical information, etc. can also be incorporated

Specimen	Row	Testpoint	Hardness	Method	Lens	X-distance to start point
Specimen 1	Row 1	1	716	HV1	50x	0,200
		2	668	HV1	50x	0,400
		3	684	HV1	50x	0,600
		4	599	HV1	50x	0,800
		5	549	HV1	50x	1,000
		6	716	HV1	50x	1,200
		7	668	HV1	50x	1,400
		8	684	HV1	50x	1,600
		9	599	HV1	50x	1,800
		10	549	HV1	50x	2,000

Options & accessories.

Adapt the DuraVision G5 to your needs.

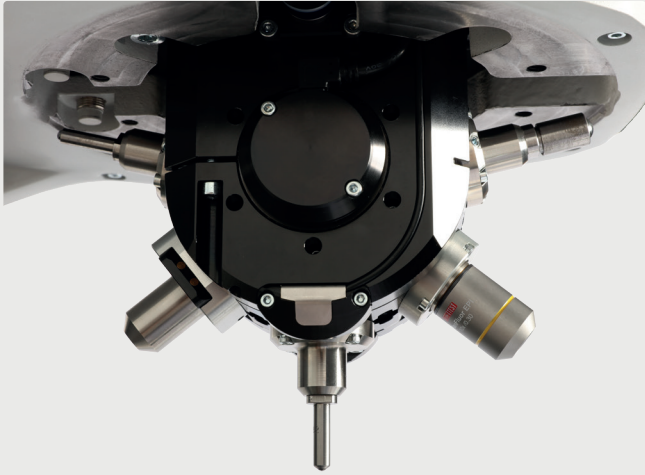

Star-shaped turret – seven at a stroke

The star turret included as standard with every machine can be expanded from the standard two positions to up to seven positions – at any time and with little effort. The star-shaped design allows not only a slim construction of the turret, but also provides seven positions for fitting any combination of indenters and lenses. A wide spectrum of test methods can thus be covered with a single machine, and frequent tool changing is not necessary. In combination with the new high-resolution camera, this reduces investment costs and set-up time. In addition, the turret rotates at a very high speed and automatically finds the shortest turning direction to the selected position.



Base – for stability and ergonomics

The DuraVision G5 base is the ideal foundation offering operators optimum working conditions. No matter if the operator works standing up or sitting down, the base provides an optimum height for ergonomic working. The base also features vibration-damping elements that provide the ideal conditions for precise measurement results. The generously sized drawers provide space for storing accessories and tools. The dimensions are 840 x 620 x 850 (WxHxD mm).

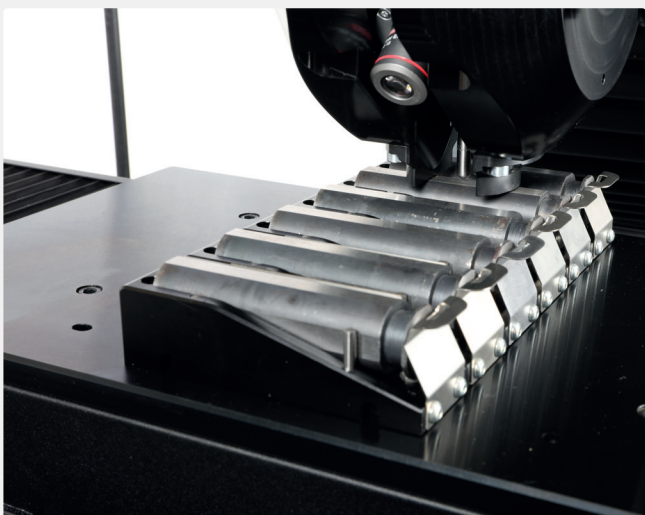

Jominy tests

With a separate software module **ecos** Workflow also guides the operator in the customary manner, step by step, to the result with Jominy specimens.

For the standard-compliant test, operators choose between HV 30 and HRC test methods in accordance with EN ISO 642 and ASTM A255 respectively. All the test parameters, including test point spacings, are predefined and guaranteed standard-compliant. For the user-defined test, operators can design the testing of Jominy specimens according to their requirements. All test methods are available for selection and users can define their own test point patterns and spacings. Multiple parallel test sequences can be created on one test surface. The result is described with all hardness values in a standardised test report. Single specimen holders are used for performing Jominy tests. The Jominy specimen holders can be combined with one another, thereby enabling up to 18 specimen holders to be placed on the cross table.

Lens with Brinell SmartLight

The Brinell hardness test has always represented a challenge with soft metals and difficult surfaces. Particularly with soft materials, the edges are not always perfectly recognisable due to considerable deformation (bulging) around the indentation. The new lenses with the innovative Brinell SmartLight now ensure ideal lighting and ensure better detectability of the indent during Brinell tests. The lenses with Brinell SmartLight are available as 2.5x and 5x lenses.

In use for Brinell testing until now

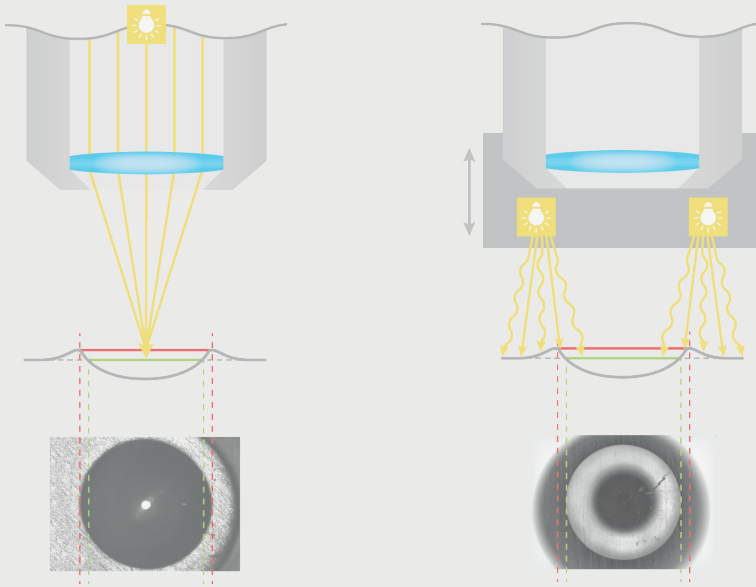

Coaxial lighting

When using coaxial lighting, the light passing through the lens is scattered on the specimen surface. As the light beams are not reflected back to the lens due to the scatter, the test indentation appears dark. Furthermore, shadowing is caused by the oblique incident light in the area of the bulging around the indent. Due to these physical factors, the edges of the indentation are difficult to detect and evaluate.

Circular light

When using circular lighting, diffuse light falls in a ring pattern from the outside onto the indentation. The light beams are reflected in the test indentation back into the lens. This allows better recognition of the edges compared with coaxial lighting. Depending on the hardness range, different height settings of the circular light are necessary in order to achieve optimum illumination of the test indentation. That these adjustments are performed manually by the operator can, however, have a negative influence on the evaluation result.

Innovation in DuraVision G5

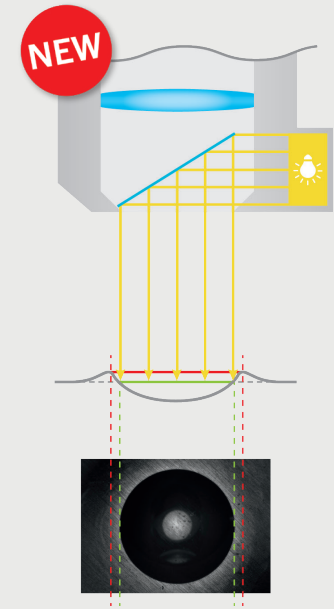

Brinell SmartLight

The SmartLight technology developed by EMCO-TEST combines a lens with “collimated light”. With this lighting, parallel light beams are directed by a mirror system onto the test indentation. The light therefore strikes the test indentation perpendicularly from above and prevents any shadowing in the area of the bulge. The contour is clearly recognisable and the indentation can be precisely evaluated. The SmartLight technology is permanently integrated into the lens and requires no further settings by the operator.

Complete accessories catalogue at www.emcotest.com

At www.emcotest.com you will find the whole range of accessories for the DuraVision G5 hardness testing machine, such as various indenters, special test tables, adapters for further indenters, lenses and much, much more.

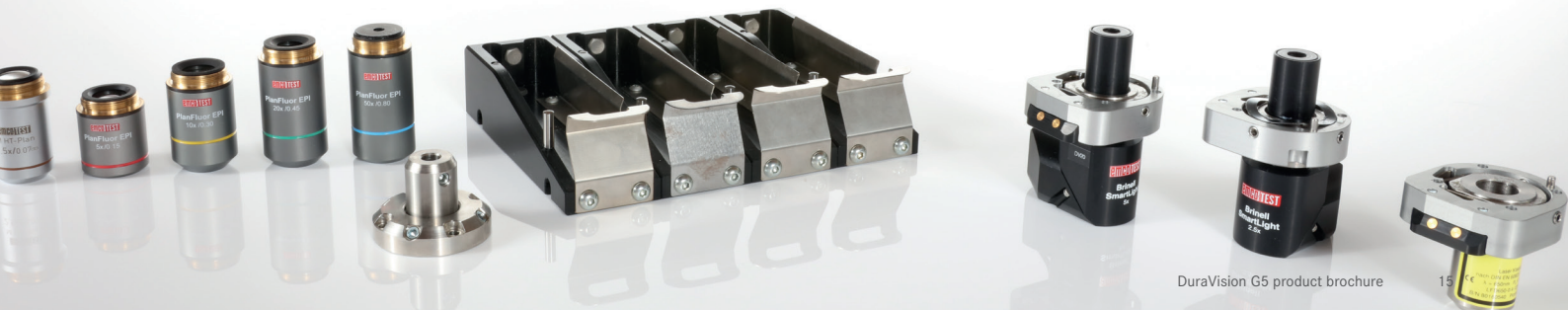

LOOKING BACK ON OVER 65 YEARS OF COMPETENCE.

Competence and experience – hand-in-hand.

Our success is founded on the vision of Karl Maier to build hardness testing machines that «do everything simply, rather than simply everything». In the form of simple testing tools that implement the most complicated functions. This is why Salzburg businessman and mechanical engineer Maier decides to establish a hardness testing department in his company, Maier & Co Maschinenfabrik (later EMCO Maier GmbH), in 1954.

When Karl Maier dies in 1978, his innovative testing products have long since made a name for themselves. The founder's son, Ernst Alexander Maier, takes over the company, which under his leadership becomes a technological leader in the field of hardness testing, not only in Austria, but far beyond its borders. 1989 marks a milestone with invention of a closed-loop control system for load application in hardness testers. For the first time worldwide, it enables testing with all test methods and many load levels in a single universal hardness testing machine. Patent applications are submitted for this revolutionary invention not only in Europe, but also in

the USA and Japan, and it still represents the technological basis for all modern hardness testers. In 1996, the hardness testing department becomes a separate company and EMCO-TEST Prüfmaschinen GmbH is founded.

The death of Ernst Alexander Maier in the year 2001 is a grievous loss, because his extraordinarily visionary spirit has not only shaped the development of the company, but also its employees and milieu. His humanity and sense of responsibility with respect to the region and the environment are also sorely missed. The figures for themselves: Approximately 50 employees at the company headquarters in Kuchl subsidiary are responsible for our international commercial success. Together with our motivated and talented team, we have turned Karl Maier's vision into a living reality – his idea has become our mission. Or to put it another way: «We don't make simply everything for hardness testing, but we do make everything in hardness testing simple.»



Premium quality with certified quality promise (ISO 9001)

In order to ensure that only perfect quality is supplied to you, every EMCO-TEST testing machine is thoroughly and stringently tested before delivery. The ease of service is taken into consideration right from the beginning in the design phase. The results are menu-driven fault detection, integrated self-diagnosis and modular exchange of electronic components that ensure the remedying of faults in a minimum of time. Software updates that take into consideration changes in standards or optimise future processes ensure high investment security for you.

Remote Support

The TeamViewer Client integrated as standard can be started directly from ecos Workflow and offers the optimum basis for perfect online support worldwide. This software allows remote maintenance as well as the sharing of the screen contents with other computers, e.g. for training purposes (internet connection required).

10 years spare parts availability

For EMCO-TEST hardness testing machines we guarantee spare parts availability of least 10 years after a product has been discontinued. To secure your investment in a EMCO-TEST testing machine, we extend this availability by several more years whenever possible, significantly exceeding standard industry requirements.



Technical data



Automatic

	DuraVision 250 G5	DuraVision 350 G5
Methods and load range		
Load range 2.942 - 2,452 N (0.3 - 250 kgf) - electronically controlled	•	-
Load range 29.42 - 29,420 N (3 - 3,000 kgf) - electronically controlled	-	•
Brinell (ISO 6506, ASTM E10)	•	•
Vickers (ISO 6507, ASTM E384, E92)	•	•
Rockwell, Super Rockwell (ISO 6508, ASTM E18)	•	•
Knoop (ISO 4545, ASTM E384, E92)	•	-
Plastics testing (ISO 2039)	•	-
Configuration		
ecos Workflow Pro operating software	•	•
Automatic test cycle with brightness control, autofocus and image evaluation	•	•
3 step zoom	•	•
12 Mpix evaluation camera with CMOS sensor	•	•
12 Mpix overview colour camera with active lighting and included panorama function		
Machine control via integrated PLC	•	•
Motorised height adjustment of the test unit with rapid traverse	•	•
Clamping force setting 1,961.4 - 19,614 N(200 - 2,000 kgf) ±10%	•	•
Automatic 2x star-shaped turret	•	•
Automatic 7x star-shaped turret	optional	optional
Surface lighting (integrated into nose cone, dimmable)	•	•
Testing clamped/unclamped	•	•
Motorised cross table (WxD)	440 x 250 mm	440 x 250 mm
Software functions		
Template function	•	•
CHD, NHD, SHD and serial measurements	•	•
Calibration Information System with calibration assistant	•	•
ecos xCHANGE (XML-based interface for data connection)	•	•
Multiple specimen module for testing several specimens in one work cycle	•	•
Integrated TeamViewer client	•	•
ecos Panorama	•	•
Adjustable User Rights	•	•
ecos AUTOROW	optional	optional
ecos LINEplus	optional	optional
areaMASTER software module for generating hardness maps	optional	optional
Jominy software module	optional	optional
Interfaces		
Interfaces for PC connection	2x USB 2.0, 1x RJ45	2x USB 2.0, 1x RJ45
Functional dimensions		
Max. specimen weight	50 kg	50 kg
Weight of basic unit	500 kg	500 kg
Z-axis resolution	0.18 µm	0.18 µm
Max. speed on Z-axis	up to 25 mm/s	up to 25 mm/s
Max. test height	380 mm	380 mm
Max. throat depth	320 mm	320 mm
Nose cone support	53 x 42 mm	53 x 42 mm
Positioning accuracy	± 0,025 mm	± 0,025 mm

Machine data

Dimensions (W x H x D)	900 x 1370 x 1050 mm
Space requirements (W x D)	2200 x 1800 mm
Test force application resolution	0.45 nm
Length measuring probe resolution	0.05 μ m
Protection class to EN 60529	IP20
Voltage supply (V)	230 V 1/N/PE
110 V 1/N/PE	IP20
Max. voltage fluctuations	\pm 10%
Frequency	50/60 Hz
Main fuse (110 / 230 V)	T 6.3 A
Room temperature (to ISO/ASTM)	+5°C to +40 °C
Humidity	max. 70%
Power consumption (max./standby)	600 W / 100 W

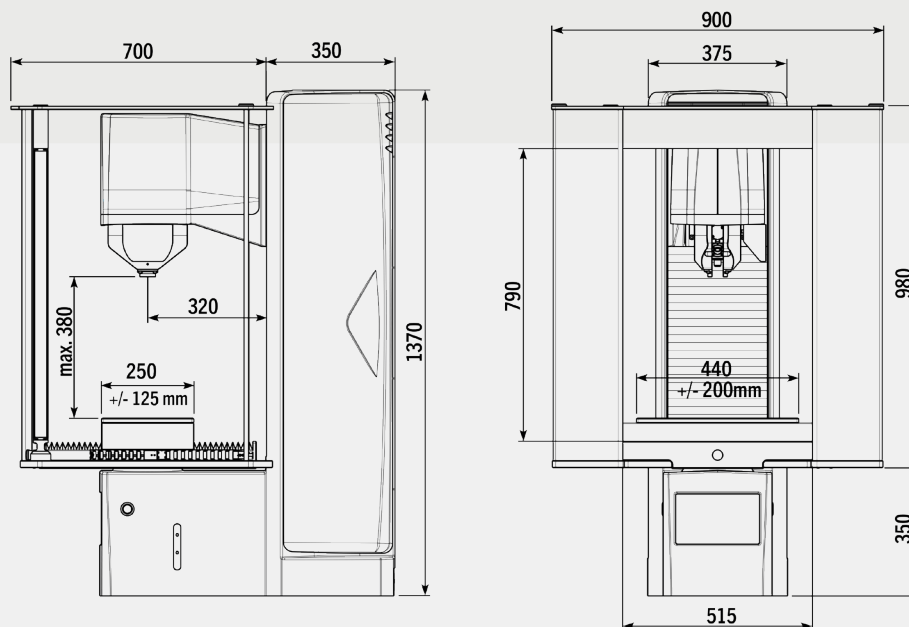

Technical and design modifications as well as printing and typesetting errors reserved. Deviations from the illustrations in colour and form reserved. In some cases the machines/equipment illustrated or described include special options that are available only at additional charge. The equipment scopes and configuration possibilities described in this brochure with respect to the standard equipment and special options for individual machines may differ from country to country. Please check out the standard equipment and special options available in your country with your local EMCO-TEST dealer in advance. Please note at all times: The systems function only within the system limits and support the customer in hardness testing. The responsibility for compliance with national standards and laws remains with the operator of the hardness testing machine.

Benefit from our global sales and service network!

You can find your local dealer on our website www.emcotest.com.



• Austrian head office

More on emcotest.com

EMCO-TEST

EMCO-TEST Prüfmaschinen GmbH

Kellau 174

5431 Kuchl-Salzburg/Austria

office@emcotest.com Tel. +43 6244 204 38

www.emcotest.com Fax +43 6244 204 38-8

