



DuraScan G5

**Precision in a nutshell.
Maximum efficiency for your laboratory**

0.00025–62.5 kgf
Vickers
Knoop
Brinell

The right device for every application.

in the load range from 0.25 g to 62.5 kg.



DuraScan 10 G5

- Control via touchscreen
- Manual 3-position measuring turret



DuraScan 20 G5

- Control via touchscreen
- Automatic 6-position measuring turret
- Manual cross slide

HALBAUTOMAT



DuraScan 50 G5

- Control via PC
- Automatic 6-position measuring turret
- Linear table



DuraScan 70 G5

- Control via PC
- Automatic 6-position measuring turret
- Linear table
- Overview camera



DuraScan 80 G5

- Control via PC
- Automatic 6-position measuring turret
- Large linear table
- Overview camera

VOLLAUTOMAT

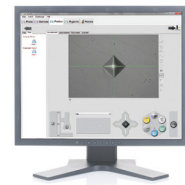

Vickers

compliant with ISO 6507, ASTM E384, ASTM E92

HV 0.00025	HV 0.0005	HV 0.001	HV 0.002
HV 0.003	HV 0.005	HV 0.01	HV 0.015
HV 0.02	HV 0.025	HV 0.05	HV 0.1
HV 0.2	HV 0.3	HV 0.5	HV 1
HV 2	HV 2.5	HV 3	HV 5
HV 10	HV 20	HV 30	HV 50
HV 60			

Conversion to DIN EN 50150, ISO 18265, ASTM E140



Knoop

compliant with ISO 4545, ASTM E384, ASTM E92

HK 0.00025	HK 0.0005	HK 0.001	HK 0.002
HK 0.003	HK 0.005	HK 0.01	HK 0.015
HK 0.02	HK 0.025	HK 0.05	HK 0.1
HK 0.2	HK 0.3	HK 0.5	HK 1
HK 2			



Brinell

compliant with ISO 6506, ASTM E10

1/1	1/2.5	1/5	1/10
1/30	2.5/6.25	2.5/15.6	2.5/31.25
2.5/62.5	5/25	5/62.5	

■ With optional load expansion above 0.25 g

The DuraScan G5 Series.

High-tech for your laboratory.

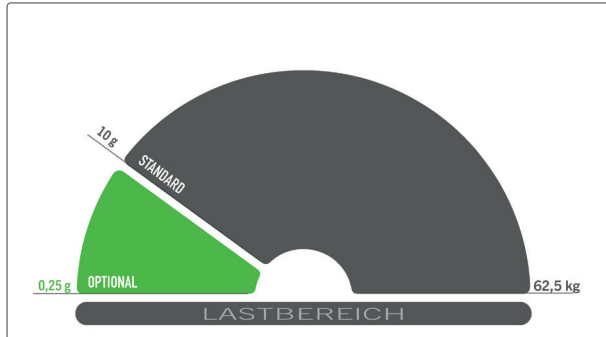

Force application via closed-loop control system

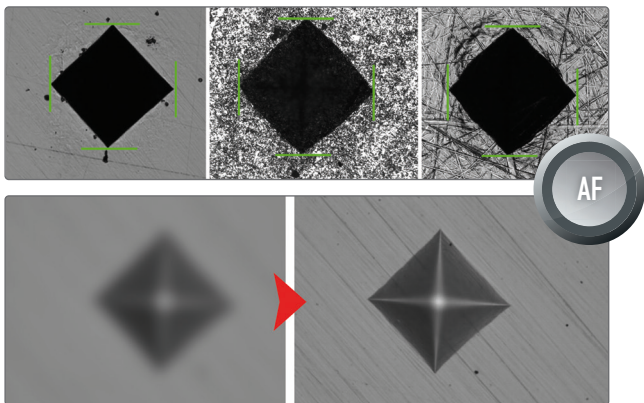

Autofocus and automatic brightness control



Patented height adjustment with rapid traverse

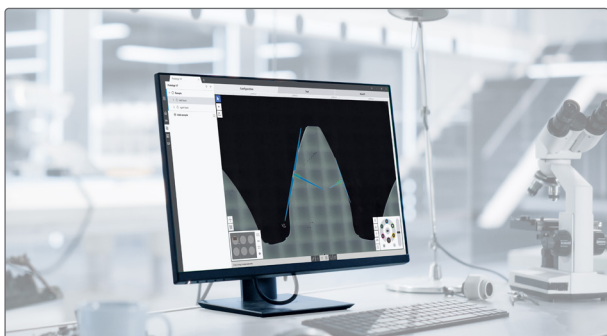

Precision and a broad spectrum of applications

The pioneering standard load range of the DuraScan G5 from 10 g to 62.5 kg expands the application range of the hardness tester enormously. This can be extended optionally to the range from 0.25 g to 62.5 kg – even subsequently at any time!

The force is thereby continuously and precisely monitored electronically using a series of electronic force measuring sensors. G5 – the fifth generation of electronic load application.

12.0 MEGA
PIXELS
CMOS

Innovation in image evaluation

The 12 Mpix camera employed in all devices of the DuraScan G5 Series sets new standards in image quality. The intelligent use of the high-resolution camera chip allows a 3x zoom without having to accept any loss in quality due to interpolation. This innovative solution allows a wide range of applications to be covered with a small number of lenses. In order to make full use of this potential, the DuraScan G5 uses only lenses that offer maximum optical resolution. The proven fully automatic evaluation reliably regulates the brightness of the image and automatically evaluates the indentation.

Accelerate your processes

The innovative solutions of the DuraScan G5 Series help to save time. Thanks to the new and patented rapid traverse for the height adjustment, the height of the test head can be adjusted at 10x speed. That saves precious time when adjusting to different specimen heights. The use of templates significantly reduces the work for the operator and increases the safety and efficiency of the testing process by minimising sources of errors in application. All settings for the hardness test, such as Test type, method, objective, limit values, test point patterns etc. can be saved as a template in each workflow step and reloaded at any time.

Innovative software solutions

EMCO-TEST offers efficient and intelligent solutions for all classic hardness testing tasks. The user is guided intuitively through the process from test preparation to the presentation of results. Clear structures and the ability to restrict functions for defined users shorten the familiarisation period and prevent user errors. In-house development guarantees our customers optimum support. Regular updates take account of changes required by standards and add new functions.

Important functions at a glance.

User friendliness and efficiency are of the highest priority.

Maximum working range per lens

Only lenses of the highest quality and with a large field of view are employed in the DuraScan G5. Perfect use can be made of these thanks to the use of a 12 Mpix camera. Flexible use of the camera sensor thus allows even more zoom levels per lens.

The investment and tooling costs are reduced.

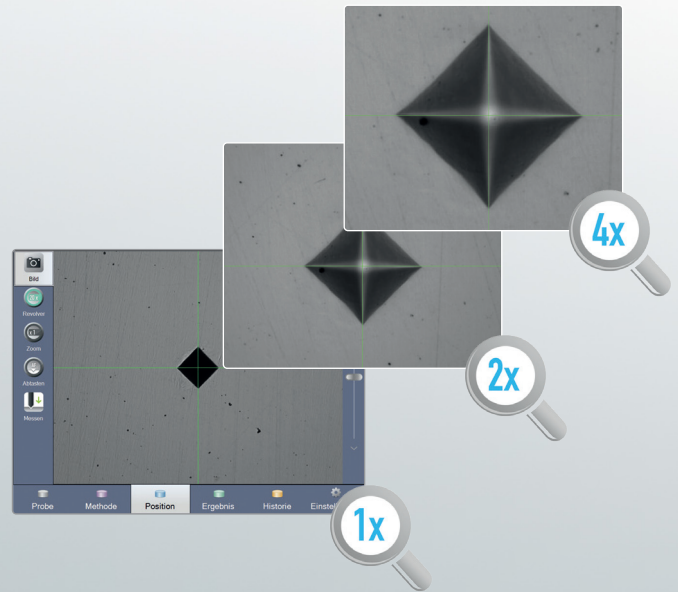

Simple management of user rights

The **ecos** Workflow operating software offers the possibility of selectively and individually controlling user rights by means of user levels.

Any number of user levels with different rights can be created and changed at any time. All available rights can be very easily assigned to the desired user level with the help of a rights editor. The users are then assigned to the user level that can, if necessary, be additionally protected by means of a password. This ensures that only authorised users can perform a measurement with the required test method or can change machine settings.



Collision detection

All our DuraLine machines are equipped with collision detection as standard. This has been developed to ensure your safety and the functionality of your machine. It recognises potential collisions to prevent damage to your machine. With this advanced technology, we minimise the risk of unexpected damage that could lead to significant repair costs or downtime.



DuraScan 10 G5 and 20 G5 – semi-automatic.

Very simple operation for basic tasks.



Fig.: DuraScan 20 G5

Fast height adjustment

The proven height adjustment of the test head allows a constant and ergonomic working height. The rapid traverse helps to significantly accelerate the adjustment to different test specimen heights. The scanning function ensures automatic positioning of the test head to the perfect working distance – the camera image is immediately sharp.



Modern display

The machine is operated via a modern capacitive 10" touchscreen with brilliant image reproduction. The surface made from mineral glass is significantly more resistant to scratches than plastic surfaces.

It goes without saying that only components are employed that have been developed for use in an industrial environment.

Cross table or planular table

With its round table, the DuraScan 10 G5 offers the prerequisites for quick and easy individual measurements. For the Dura-Scan 20 G5, the series is extended by a manual XY cross slide (135 x 135 mm). Reliable progression measurements are therefore possible. Digital spindles are also available as an option.

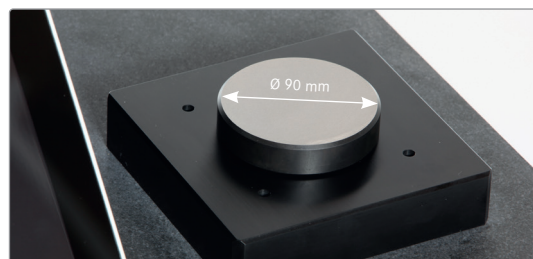

Test table DuraScan 10 G5

The pioneering hardness testing software.

ecos Workflow Touch

The workflow in five steps

Specimen, method, position, result and history are the five steps provided by the intuitive **ecos** Workflow operating software.

Logic, transparency and very simple operation are the key factors in the workflow for efficient and convenient hardness testing. Available as standard in 13 languages.

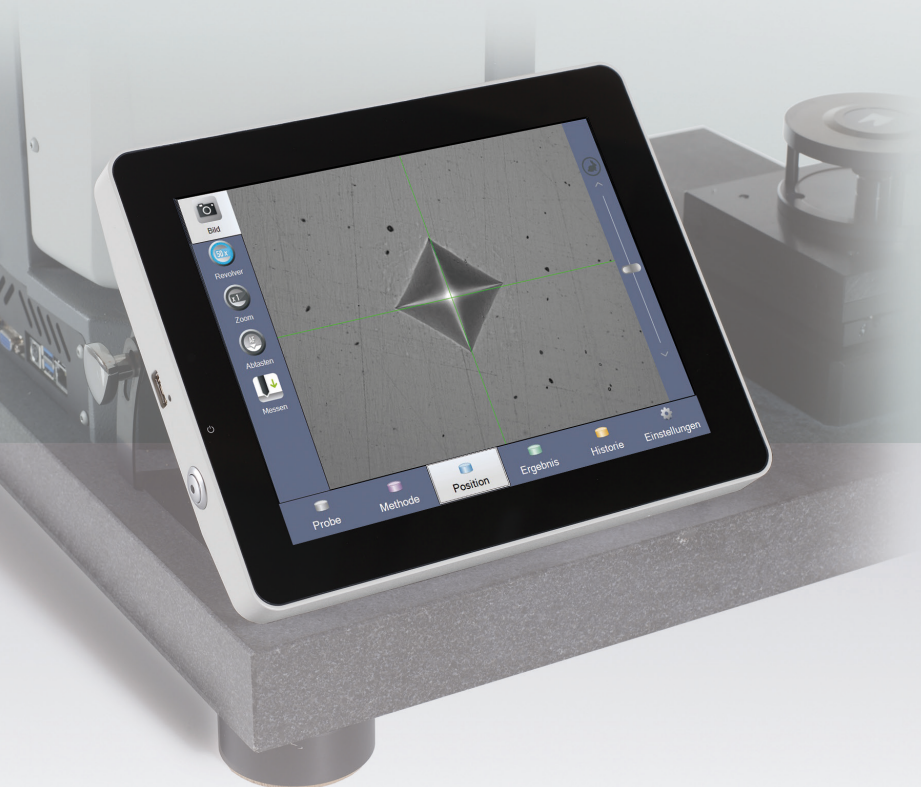
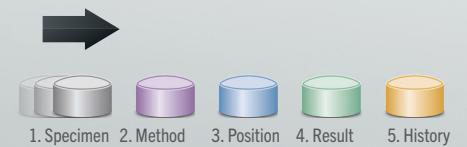

1 Specimen

Select the required test type. In addition to individual measurements, the DuraScan 20 G5 also offers serial measurements, CHD, Rht or Nht curves.

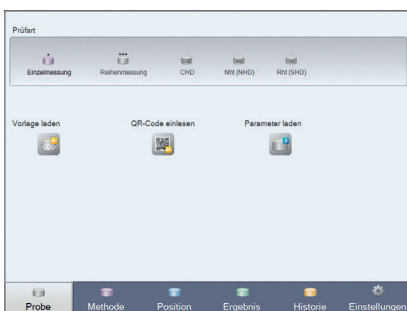

2 Method

Select the test procedure, lens, test method, zoom level and, if applicable, conversion, limits and geometric correction according to standard as well.



3 Position

Position your test point on the workpiece. This is child's play with the tools provided. Then start the test.

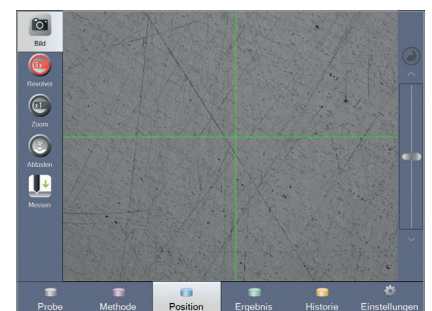

Serial measurements

A test point wizard is available for serial measurements or CHD, Nht, Rht measurement. This assists you in creating a test point grid for standard-compliant serial measurements (EN ISO 2639, 10328, 50 190).

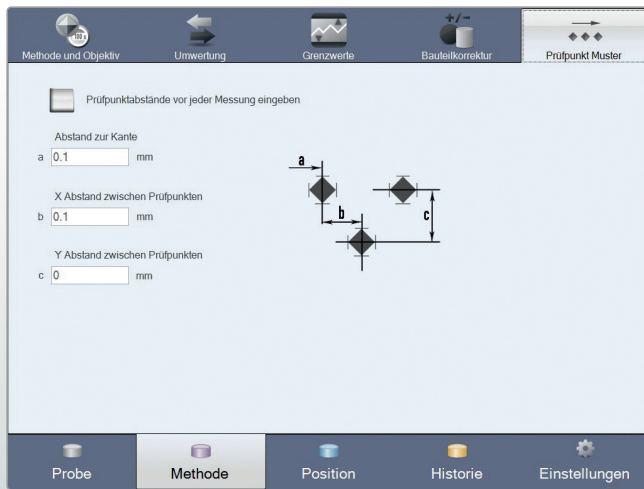

Very simple operation

The intuitive control shows you clearly which lens or which indenter is in use. The 6-position turret is swivelled by clicking on the display.



Autofocus

The automatic detection of the specimen height allows the tester to be focussed independently.

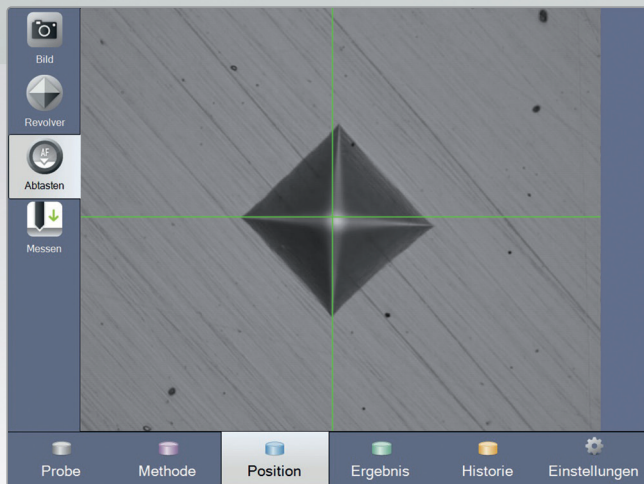

Statistics and diagrams

The measured values are displayed visually in statistics or diagrams.

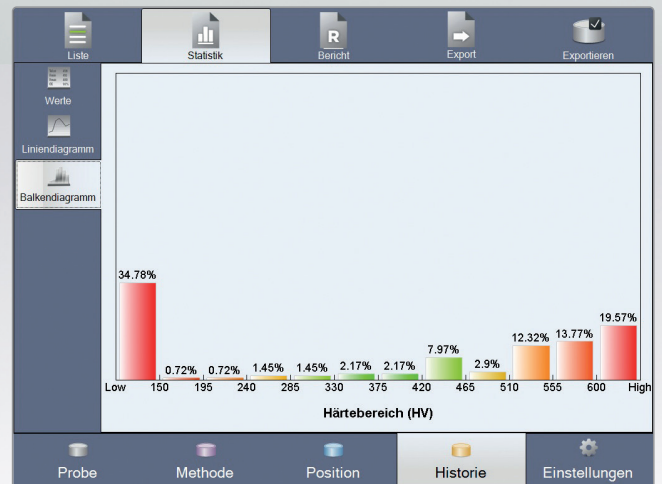

4 Result

The result is shown clearly and is available for further use. The measurement can also be repeated automatically or manually if required.

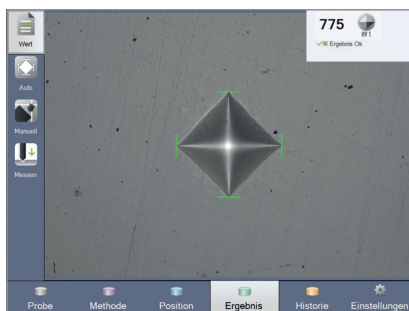

5 History

All results are stored permanently with a clear structure. You have the option of archiving the data in other systems or of creating a report via the directly interfaced printer.



DuraScan 50 G5, 70 G5 and 80 G5 – fully automated.

Highest efficiency for complex tasks.

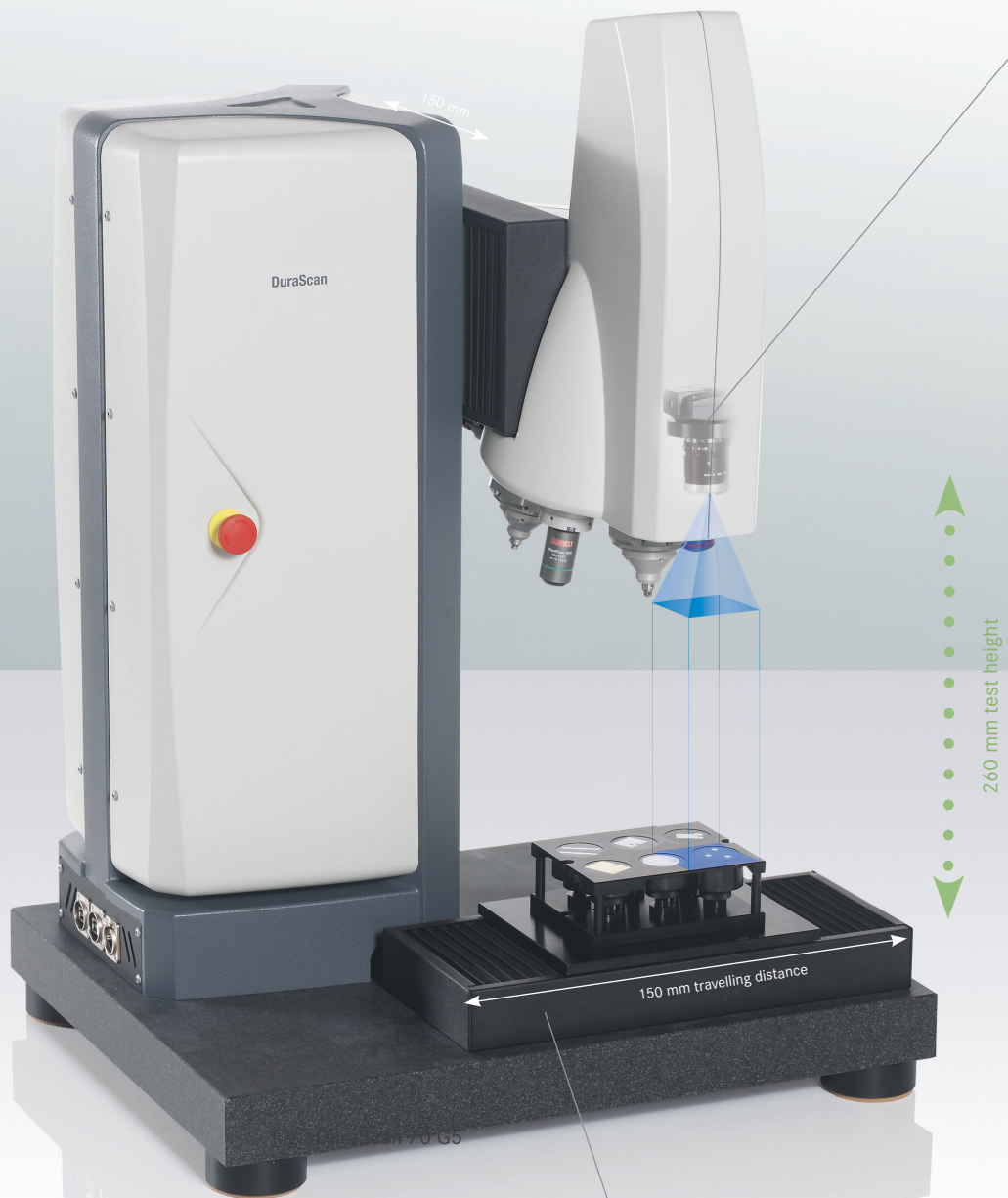

Innovative axle arrangement

The patented arrangement of both the Z-axis and the Y-axis on the test head allows a large test area with compact dimensions. This also optimises ergonomics by maintaining a constant working height.

Highest positioning accuracy

The use of backlash-free spindles and a high digital resolution of the automatic axes enable a repeatability of under $3\ \mu\text{m}$ to be achieved. The use of glass scales in the X/Y-axis enables an absolute positioning accuracy of under $0.25\ \mu\text{m}$ (optional) to be achieved.

Overview camera (DuraScan 70 G5, 80 G5)

With the overview colour camera, you have everything in view, even for complicated test procedures with several test points and progression series. The 12 Mpix overview colour camera with active LED coaxial lighting provides fundamentally new visual impressions and thus facilitates orientation on your specimens. It ensures uniform illumination and reduces the influence of ambient light, which is a major advantage, especially in workplaces with difficult lighting conditions. The high-resolution colour reproduction makes even the smallest details visible and significantly improves your work process. Compare different image displays (ambient light, coaxial lighting and HDR view) and select the optimum display for your specific sample.

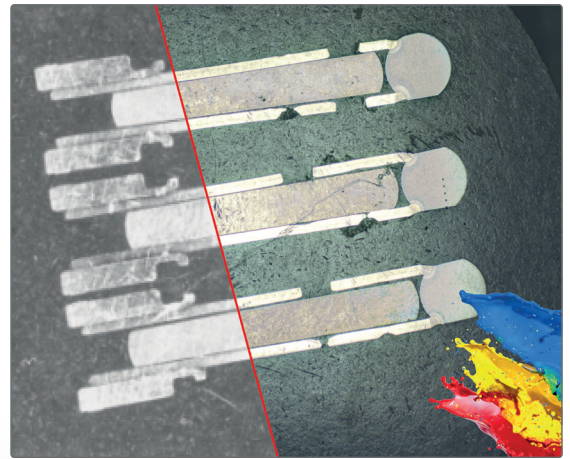

Comparison black and white camera / colour camera

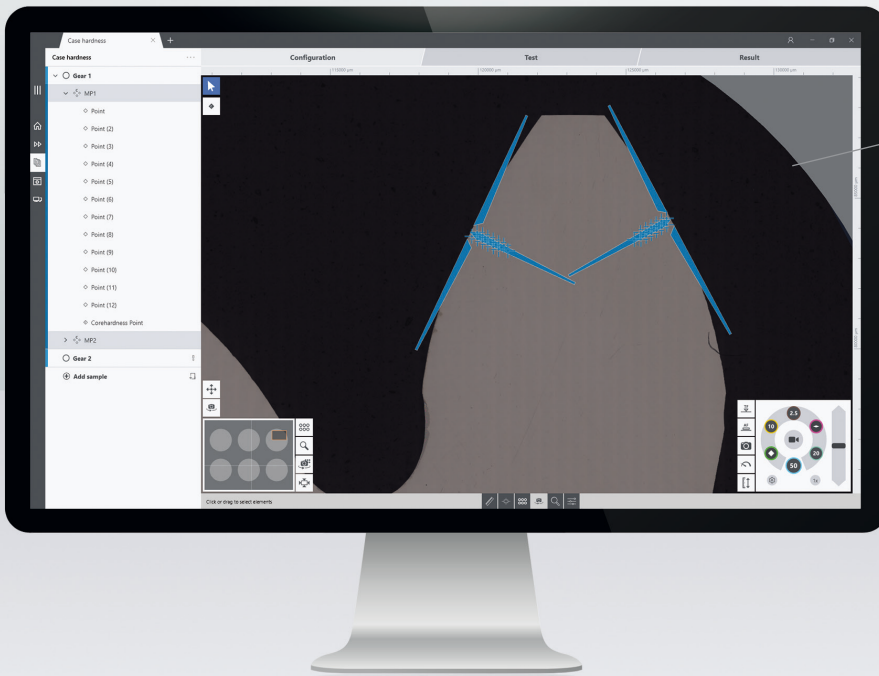

Intuitive operation

The game is controlled by means of a connected PC with mouse and keyboard.



DuraScan 80 G5 with large testing table

The DuraScan 80 G5 variant has a significantly larger test area. With the 300 mm travel distance of its X-axis, up to 12 specimens in two specimen holders can be positioned and processed at the same time. The useful working area is increased to 300 x 150 mm. The base for this device is a solid granite slab measuring 700x450 mm.

ecos III Next-level efficiency.

The most efficient hardness testing software.

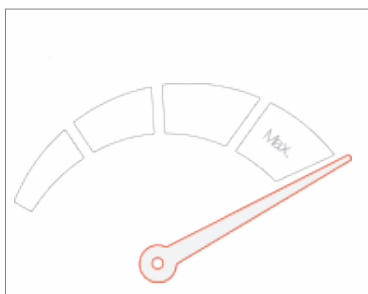
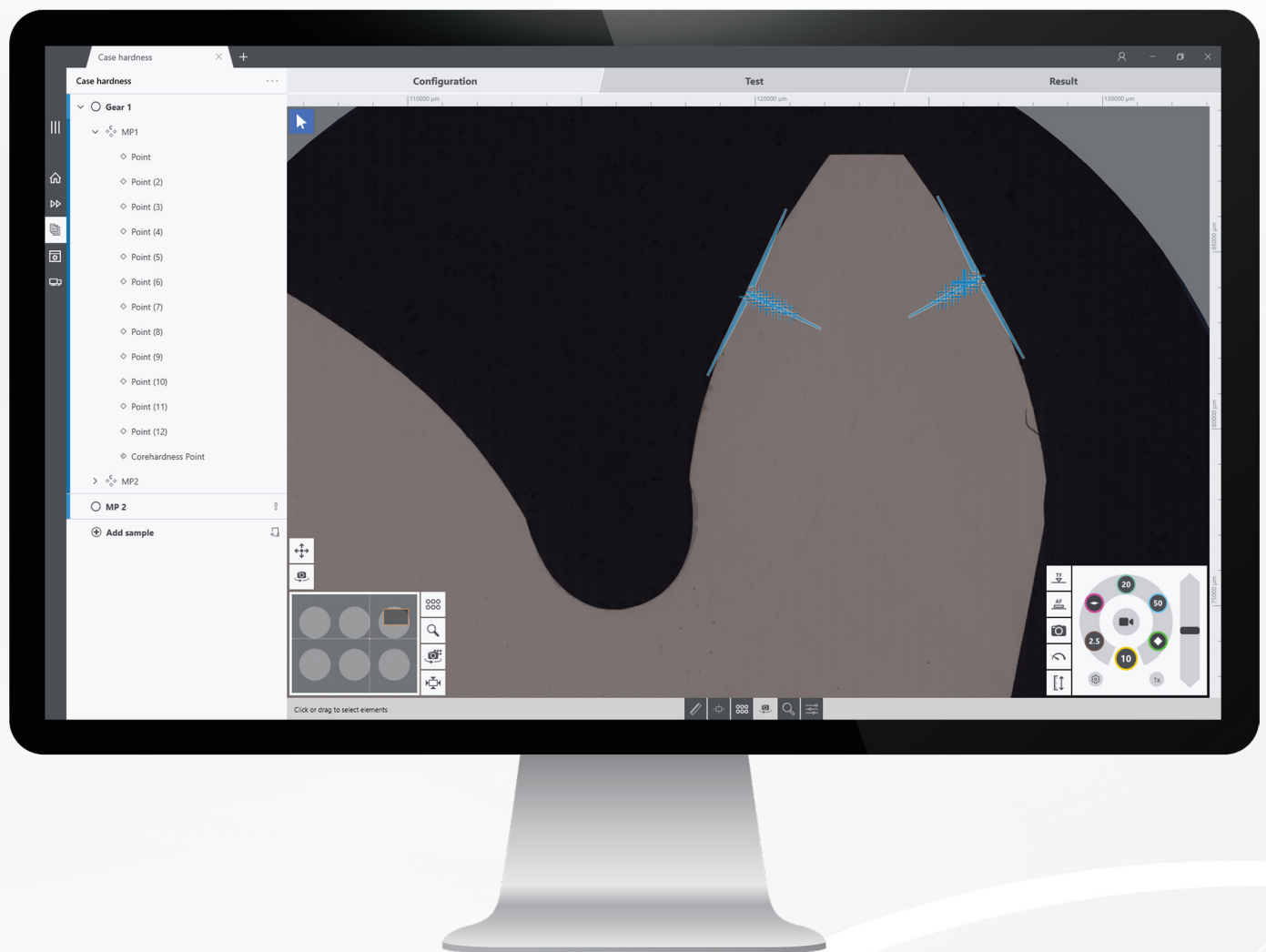

Efficient

With **ecos III** you benefit from a sophisticated operating concept in which all processes have been optimised. This cuts the **operating time** by up to **65%**, and the number of staff required for the test.



Simple

Thanks to an intuitive operating structure with simple rules, quick familiarisation is no problem. Even complex and extensive test patterns can be defined and placed on the sample with just a few clicks.

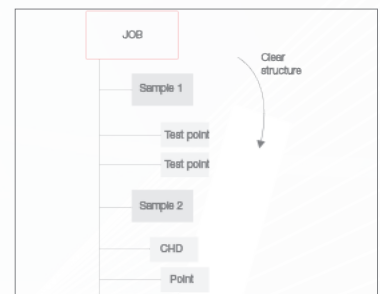

Clear

With **ecos III**, the overview takes centre stage. All test elements are distinctly divided into jobs and specimens. This keeps everything clear, even with large amounts of data, and allows test reports to be created for multiple specimens and trend analyses.

The hardness testing software that exceeds standards.

Our passion for perfecting testing software, which began with ecos Workflow, has reached new heights with the successor **ecos III**. The new hardness testing software **ecos III** combines **highest efficiency, simple operation** and **perfect clarity**. Inspired by years of experience with ecos Workflow, **ecos III** represents a completely new development. The software is already available for selected machines.

Welcome to the world of **ecos III** – the world’s most unique hardness testing software on the market!

Our software is based on the latest AI technology and enables reliable and time-saving evaluation of indents. But what makes **ecos III** truly unique in the field of hardness testing machines is its ability to seamlessly continue your work even while the machine is still carrying out test jobs.

In a world in which data acquisition and processing are becoming increasingly complex, **ecos III** keeps you on top of things. You can summarise test data into orders, for example to document the quality of components over a longer period of time or to structure the test data of groups of people. A multitude of helpful tools enables precise positioning of test points and test series. Thanks to the ability to save recurring test settings as a template and flexibly reuse them, you can increase your efficiency and precision to an unprecedented level.

ecos III – the future of hardness testing software is already a reality with us today. Increase your productivity, save valuable time and experience the revolution in hardness testing.

The work area is divided into three sections:

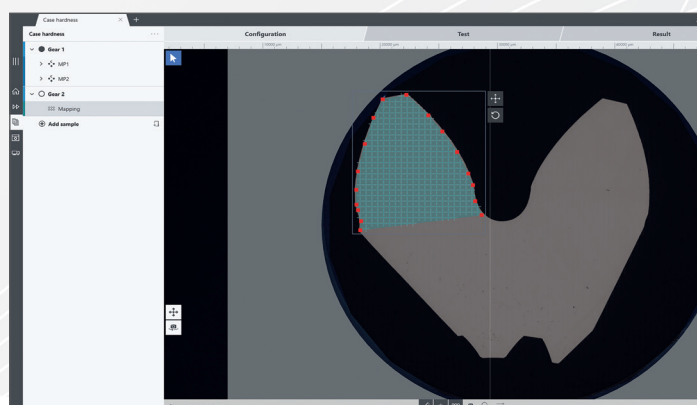

1. Configure Check

Create the elements for your samples, such as test points and test series, in the respective order according to your specifications and place them on the panoramic image. Select the appropriate test specification (e.g. for CHD series), set the necessary parameters such as method, revaluations, test point pattern and limit hardness and place the elements on your samples.

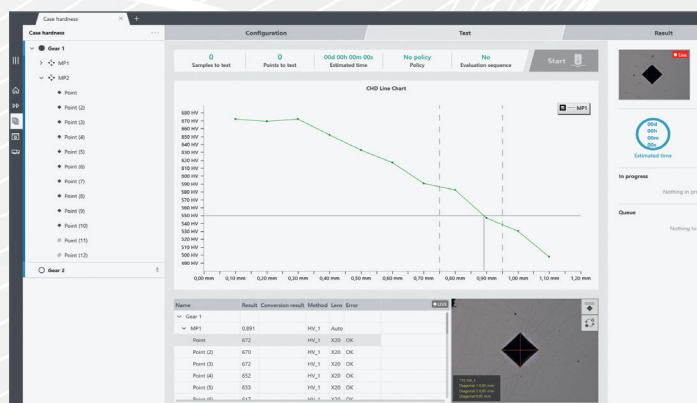

2. Perform Check

Check your test settings such as the standard to be used or the test sequence, change the order of the samples to be tested and start the test. Maintain an overview of the ongoing measurement and correct the evaluation during the measurement if necessary. Thanks to the use of reliable AI-based impression detection, this will only be necessary very rarely.

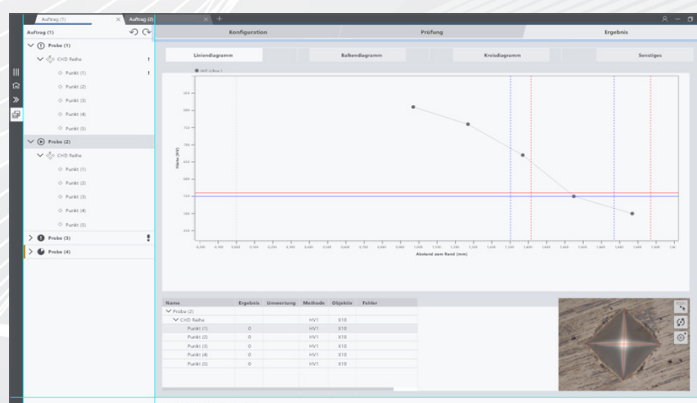

3. Analyse Results

Summarise the results of one or more samples of an order, create trend analyses, reports or export your data as xlsx or txt files. Design your test reports with the integrated and very easy-to-use Report Designer.

Important functions.

ecos™ III

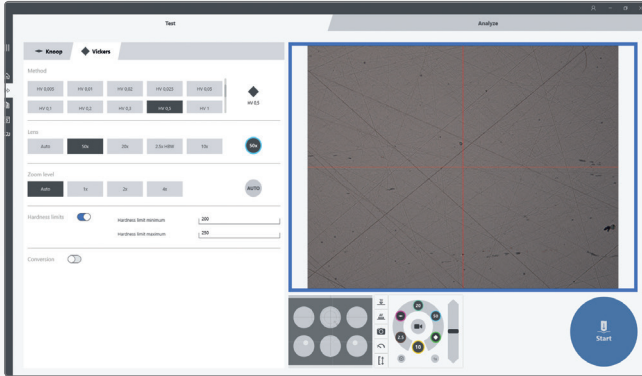

Just a quick check?

For simple tasks, there is the uncomplicated "Quick Mode". Define only the required method, optionally revalue and find the appropriate check-points. The results are recorded in a clearly organised list and can also be printed or exported.

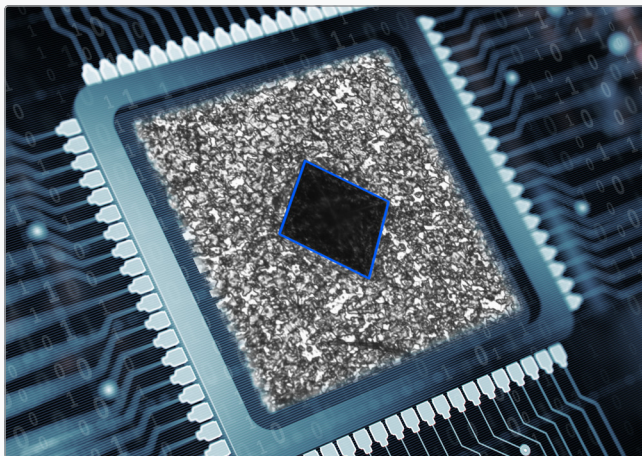

Improved evaluation of impressions

The newly developed method for analysing hardness impressions is based on artificial intelligence and recognises the impressions even when scratches or dirt cause conventional algorithms to fail. Very good results are achieved even on etched surfaces.

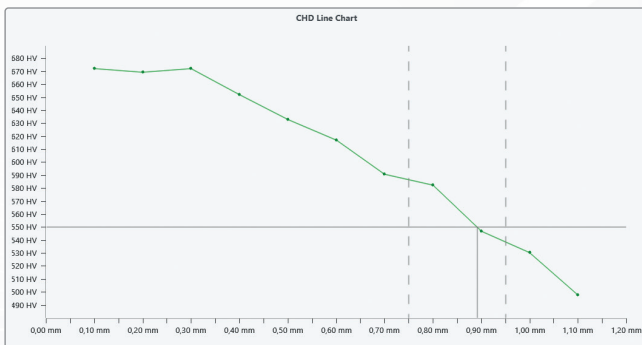

Hardness curves - quick and easy

Select the gradient tool and place any number of test series on your component quickly and precisely with 2 clicks per row. Frequently used settings can be saved as templates, saving additional time and avoiding operating errors. Test point patterns can be easily created in the editor or specified via parameters.

Work with your hardness tester

Efficient work is demonstrated not only by the well thought-out processes that support the user even with complex tasks, but also by the fact that work does not have to be interrupted when the hardness tester is running and processing samples and test series fully automatically. This means that test impressions can be measured manually, results can be analysed and test reports can be created. Another advantage is that new inspection tasks can be defined at the same time and added to the queue of pending inspections.



Extensive template mode

Templates can be easily created for recurring inspection tasks, which can then be loaded at any time. This simplifies and speeds up operation and, above all, effectively prevents operating and setting errors. Templates can be created for entire samples, series and test samples.

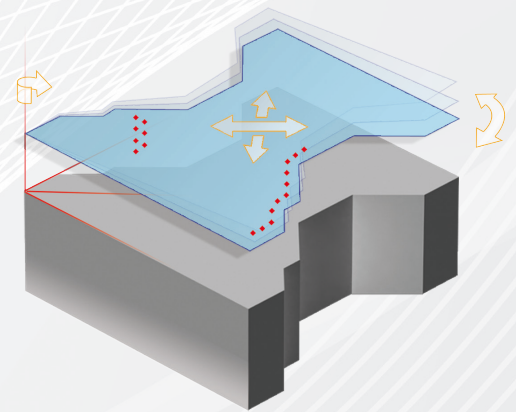

Organisation of the test data

All test results are grouped into samples. Each sample contains test series and individual hardness impressions. Samples can also be bundled into test orders. This structure enables a clear presentation of the test results for each physical sample that is Test reports can be presented. In addition, orders offer the possibility of creating trend analyses over longer periods of time or consolidating the test data of specific customers or employees. This ensures that you always have a comprehensive overview.

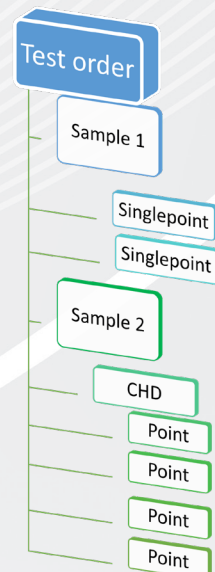

State-of-the-art data management.

Simple and safe handling of data.



Efficient data management

As pioneers in Industry 4.0, the DuraScan G5 models are equipped with industrial PLCs and optimised for intelligent manufacturing environments.

In addition to the direct creation and saving of test results, data can be exported individually in various formats such as .pdf, .xls, .csv or .xml using the Export Editor. A connection to Q-DAS systems via .dfq file is also possible. The measurement results can be automatically exported to the internal network of ERP and quality systems, such as SAP, Q-DAS, MES, LIMS. Internet-based remote maintenance and an integrated calibration information system make these machines future-proof.

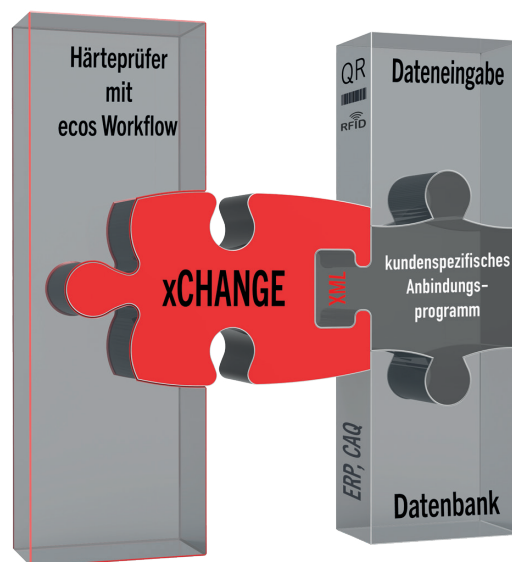

ecos xCHANGE

The **ecos** xChange interface is a standard feature of all DuraScan and Duravision hardness testers. Using these, each hardness tester can be integrated into production lines and communicate with customised software. The XML format-based data makes handling simple and structured.



Create individual test reports

All models offer as standard the possibility of direct printing. This function allows a test report to be created using an interfaced printer. With the DuraScan 70 G5 and 80 G5 models, a sample image created with the overview camera can be integrated (see example below). Furthermore, the flexible report generator enables easy individual reports to be designed for documentation of the test results.

Integration of your company logo into the test report

Individual fields for specimen designation and test parameters

ecos CAPTURE generates sample images that can be used in the report or saved separately. Select which additional information such as test points, row start point or reference points are to be displayed in the image. With the **ecos LINEplus** add-on module, you can place test points easily and precisely by using guide lines. The auxiliary lines and the measurement results can also be displayed in the image.

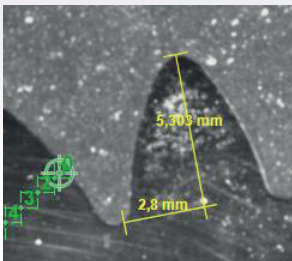

PRÜFBERICHT

Probenbezeichnung: Sample Testmethode: HV 1 Umwertung: --- Messdatum:	Benutzerfeld1 Benutzerfeld2 Benutzerfeld3 Benutzerfeld4 Benutzerfeld5 Benutzerfeld6
--------------------------------------------------------------------------------	----------------------------------------------------------------------------------------------------

Datum: _____ Unterschrift: _____
 Datum: _____ Unterschrift: _____

Further freely definable fields

Bar diagram, statistics, trend diagram, etc.



Measured value tables, statistical information, etc. can also be incorporated.

Probe	Reihe	Prüfpunkt	Härte	Methode	Objektiv	X-Abstand zum Startpunkt
Probe 1	Reihe 1	1	716	HV1	50x	0,200
		2	668	HV1	50x	0,400
		3	684	HV1	50x	0,600
		4	599	HV1	50x	0,800
		5	549	HV1	50x	1,000
		6	716	HV1	50x	1,200
		7	668	HV1	50x	1,400
		8	684	HV1	50x	1,600
		9	599	HV1	50x	1,800
		10	549	HV1	50x	2,000

Options & accessories.

Adapt the DuraScan G5 to your needs.



Optional load range from 0.25 g

On all DuraScan G5 hardness testers, the total test load per indenter can be optionally extended to the range from 0.25 g to 62.5 kg. The load range below 10 g makes high technical demands on the design of the hardness tester as far as the accuracy of the application of these small forces is concerned. All DuraScan G5 devices therefore have a solid granite slab as base and legs with damping elements specially designed for the DuraScan G5 Series. These reduce the vibrations acting on the device by 50% compared with legs with conventional rubber dampers. In addition, EMCO-TEST provides precise information on the demands on the installation location with respect to vibrations.

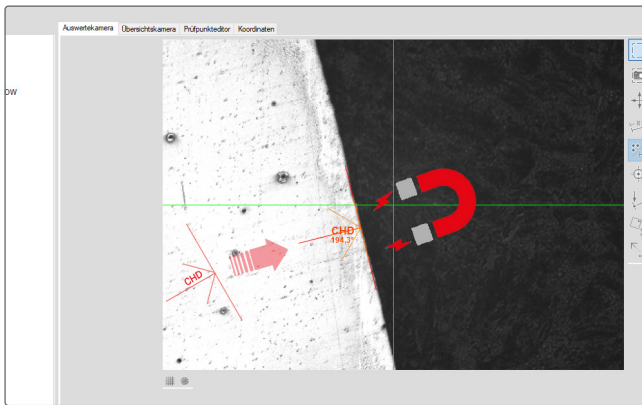

ecos AUTOROW

ecos AUTOROW enables the automatic fine positioning of test series at the specimen edge. This significantly increases the efficiency of the fully automatic hardness tester.

It allows row start points pre-positioned in the overview camera to be placed automatically at the specimen edge. The specimen edge is detected automatically and precisely in the measuring camera image, the row is shifted according to its alignment and then aligned at right angles to the specimen edge. It does not matter whether the series is positioned slightly outside or inside the sample edge; the function can be used optimally in combination with predefined samples. Since all test series are predefined, it only remains for the specimen to be aligned on the component using the specimen reference point in the live overview screen. Fine positioning is performed automatically by mouse click – with **ecos** AUTOROW.

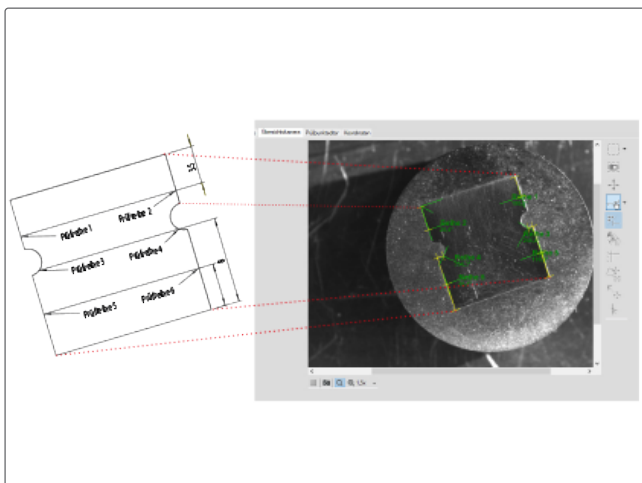

ecos LINEplus - the comprehensive Toolbox

ecos LINEplus contains a set of line tools that help to place test points and rows precisely on the sample according to the dimensional specifications. The reference line functions for length and angle allow you to quickly and easily define the position of row starting points or test points on the workpiece. They can also measure lengths and angles on the workpiece. All starting points and end points have a snap function, that allows multiple reference lines to be concatenated. However, test points, row start points and polylines can also be placed precisely in this way, based on the polylines. The extended polyline function allows test points to be distributed along a line. Multiple test point chains at different distances can be assigned to each polyline.

Polylines and reference lines can always be edited at a later time and they can also be aligned on the specimen subsequently. This makes the efficient use of templates (samples) possible.

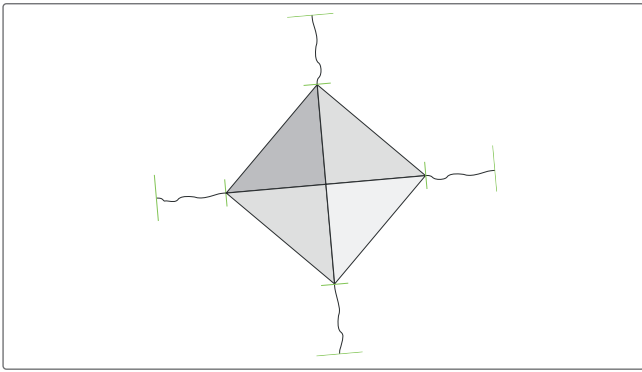

ecos FRACTURE

The optional ecos FRACTURE module enables the fracture toughness of carbide and ceramic materials to be determined quickly using the Palmqvist (ISO 28079) and Niihara (ISO 28079) methods. To determine the fracture toughness, all four individual cracks must be measured with the evaluation camera. The fracture toughness is determined automatically.

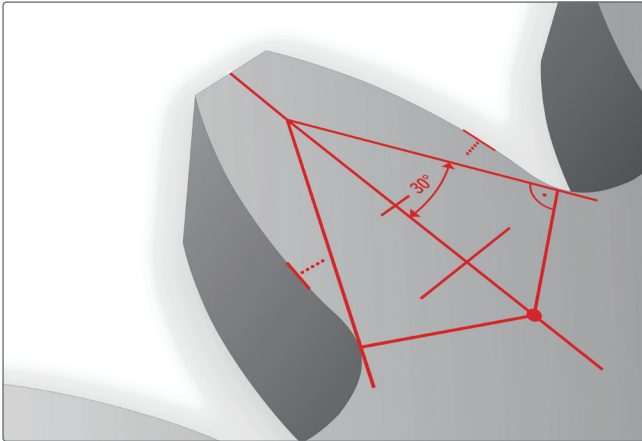

A close grilling

This optional function for all DuraScan fully automatic machines enables precise testing of gear samples. CHD, Nht and Rht rows can be set at the gear teeth, on the flanks and in the axis of the gear. The basis of the line construction is the 30° tangent, starting from the gear teeth. The core toughness point is precisely positioned via the construction. You can use the template function to check your gear quickly, efficiently and reproducibly. The tool complies with the standard guidelines for load testing the gear teeth and is available as a separate feature of the ecos Workflow software.

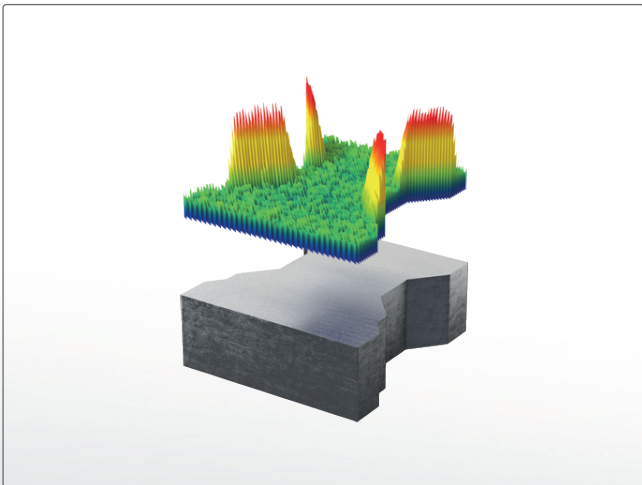

areaMaster

This optional software module is your convenient assistant when it comes to automated solutions for complex hardness testing tasks. It supports laboratory users wishing to position a large number of test points on a defined surface or along the edge of the specimen. The integrated hardness map – a colour display of the hardness distribution on surfaces – ensures the optimum visualisation of your results. Even large volumes of information, such as hardness values and coordinates of the test points, are shown clearly. With the additionally integrated Edge Assistant, a contour of the sample edge can be digitised and test points can be distributed in the scanned area. The software module is available for the devices DuraScan 50 G5, 70 G5 and 80 G5.



Brinell SmartLight

Developed by EMCO-TEST, the Brinell SmartLight solves a well-known problem in the evaluation of Brinell indentations. Particularly with soft materials, the edges of the indentation are not always immediately identifiable with conventional lenses due to considerable deformation (bulging). The frequently used ring light only solves the problem unsatisfactorily. The new lenses with the innovative Brinell SmartLight now ensure ideal lighting and allow better recognisability of the test indentation during Brinell tests. The lenses with Brinell SmartLight are available as 2.5x and 5x lenses.

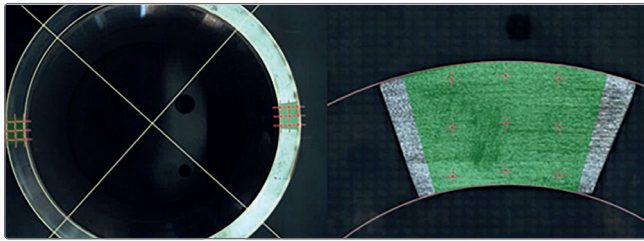

ecos pipeMASTER

With the ecos pipeMASTER software module, seamless and welded pipes and pipe segments can be hardness tested quickly and easily. ecos pipeMASTER fulfils all requirements for hardness testing on oil and gas transport systems in accordance with the applicable standards of the American Petroleum Institute (API).

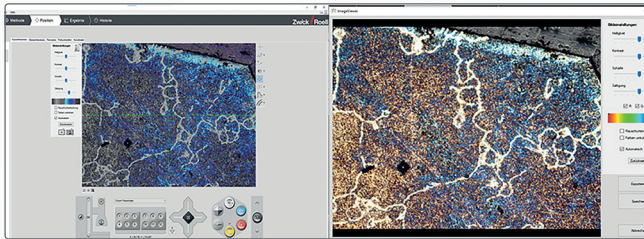

ecos imageMASTER

This software module is an interface for the Olympus Stream Desktop to enable further processing of metallographic applications. It also allows the live image to be extensively influenced by adjusting the image settings. Brightness, contrast, sharpness and saturation can be fine-tuned. It is also possible to display only certain colour spectra. This allows surfaces that are difficult to see to be made more visible.



Olympus PRECiV Desktop

Expandable image processing software for microscopy applications in industry and materials science. Includes the following functions: advanced phase analysis, basic measurement functions (distance, angles, rectangles, circles, etc.), statistics and data export to Microsoft Excel, advanced measurements (magic wand, freehand polygon and interpolated polygon), creation of reports with Microsoft Word or Excel.

Olympus PRECiV Weld offers a simple solution for performing asymmetry, multiple vertical line and A fillet weld measurements, enabling detailed and quantifiable analysis of the weld sample. These measurements are important for assessing the quality of the weld seam. The OLYMPUS PRECiV Desktop software module is required to use Olympus PRECiV Weld.

Olympus PRECiV Grain Intercept

This solution is used to manually measure the ferritic or austenitic grain sizes of steel. It provides a single averaged value using the various available standards. (ASTM E112-13, ASTM E1382-97(2015), ISO 643:2012, GOST 5639-82, JIS G0551:2013, JIS G0552:1998, DIN 50601:1985, GB/T 6394:2002). Requires Olympus PRECiV Desktop.

Other accessories

Ask your contact about further accessories for the DuraVision G5 hardness testing machine, such as various indenters, special test tables, adapters for further indenters, lenses and much, much more.

Competence in hardness testing



Production site Kuchl

Competence in hardness testing

Our success story is based on the vision of Karl Maier, who wanted to develop hardness testing machines that “don’t simply do everything, but do everything simply” – simple tools that can also perform complex functions. For this reason, the Austrian entrepreneur and mechanical engineer founded the hardness testing department at his company Maier & Co Maschinenfabrik (later EMCO Maier GmbH) in 1954.

EMCO-TEST since 1954 has stood for innovative products and services in the field of classic hardness testing and has a unique product portfolio.

10 years' spare part availability

We guarantee the availability of spare parts for EMCO-TEST hardness testing machines for at least 10 years after product discontinuation. To safeguard your investment in an EMCO-TEST hardness testing machine, we extend this availability for additional years whenever possible. As a result, we significantly exceed the industry standard.

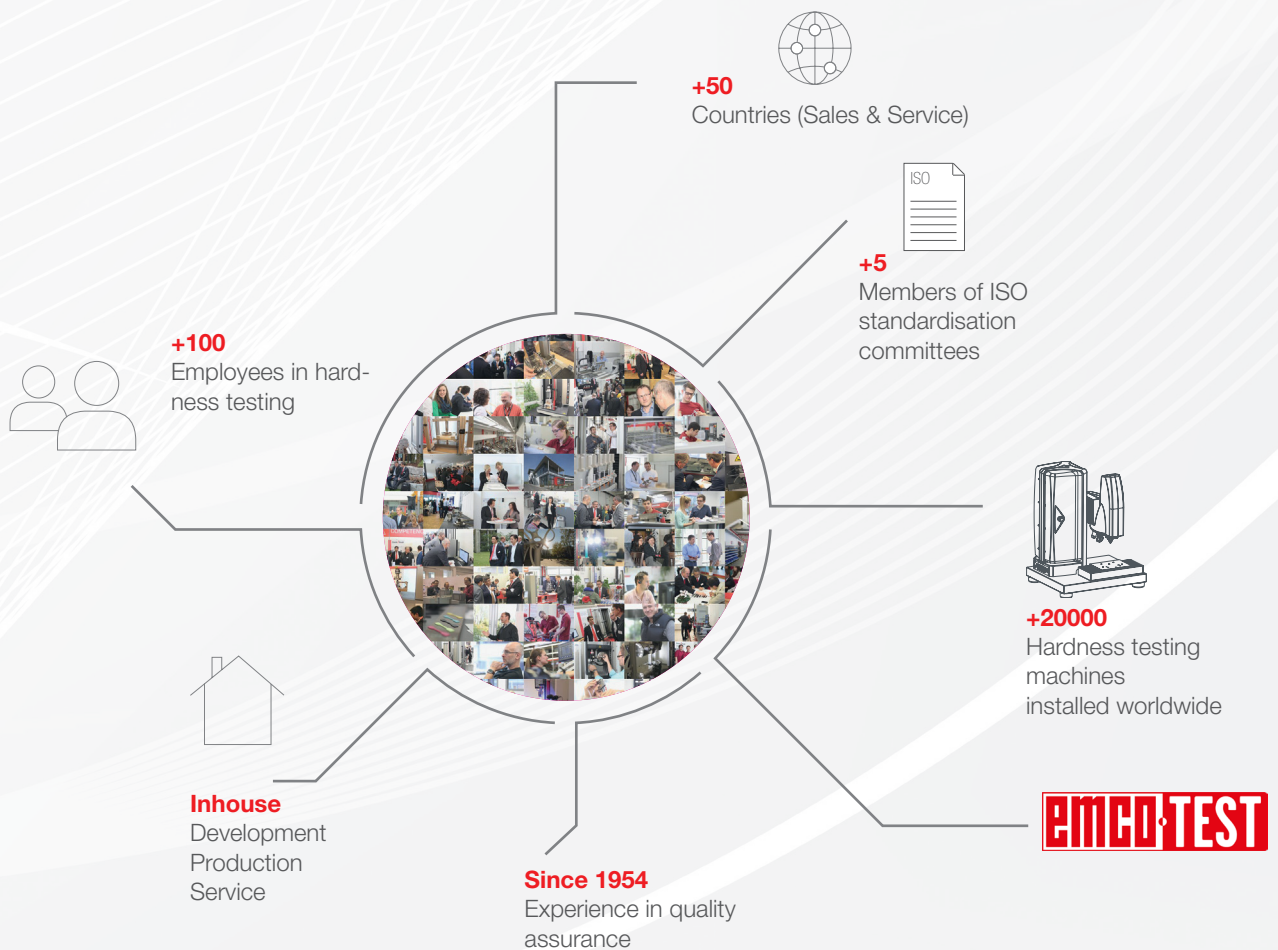

Technical data – DuraScan 10 G5 and 20 G5



DuraScan 10 G5

SEMI-AUTOMATIC

Methods and load range	
Load range 0.098 - 612.9 N (0.01 - 62.5 kg) - electronically controlled	•
Load range 0.002452 - 612.9 N (0.00025 - 62.5 kg) - electronically controlled	optional (per indenter)
Vickers (ISO 6507, ASTM E384, E92)	•
Knoop (ISO 4545, ASTM E384, E92)	•
Brinell (ISO 6506, ASTM E10)	•
Equipment	
10" capacitive colour display (800 x 600 pixels), tiltable	•
ecos Workflow Touch operating software	•
Automatic test cycle with brightness control and evaluation	•
3-step zoom	•
12 Mpix evaluation camera with CMOS sensor	•
Baseplate of polished granite	•
Legs with integrated damping elements	•
Machine control via integrated PLC	•
Motorised height adjustment of the test unit with rapid traverse	•
Manual 3x measuring turret	•
Automatic 6x measuring turret	optional
Brinell SmartLight	optional
Test table	Ø 90 mm
Manual cross table with 25 mm travel distance and analogue micrometer spindles	optional
Manual cross table with 50 mm travel distance and analogue micrometer spindles	optional
Digital micrometer spindles	optional
Operating system Windows 10/64 bit	•
Software functions	
Module for serial measurements	optional
Measurement data management / template function	•
QR code function	•
Calibration assistant	•
ecos xCHANGE (XML-based interface for data links)	•
Integrated TeamViewer client	•
User Rights Management	•
Interfaces	
Network interface	2x RJ45
USB interface 3.0	4 x
HDMI	1 x
Display Port	1 x
Integrated memory (SSD)	128 GB



DuraScan 20 G5

•
optional (per indenter)
•
•
•
•
•
•
•
•
•
•
•
•
•
•
-
•
optional
135 mm x 135 mm
•
optional
optional
•
•
•
•
•
•
•
•
•
2x RJ45
4 x
1 x
1 x
32 GB

Functional dimensions:

Space requirements (W x D)	700 x 600 (mm)
Max. workpiece weight	50 kg
Positioning accuracy with manual spindle	0.01 mm
Test force application resolution	24 bit
Max. test height DuraScan 10 G5	260 mm
Max. test height DuraScan 20 G5	235 mm
Z-axis resolution	2.6 nm
Max. speed on Z-axis	1,2 mm/sec. up to 20 mm/sec.

Machine data:

Weight of basic unit	85 kg
Dimensions (W x H x D)	550 x 700 x 450 (mm)
Protection class to EN 60529	IP20
Power consumption (max./standby)	120 W/50 W
Max. voltage fluctuations	± 10%
Main fuse (110/230V)	T6,3A
Room temperature (to ISO/ASTM)	23 (± 5)°C
Humidity	max. 70% (non-condensing)

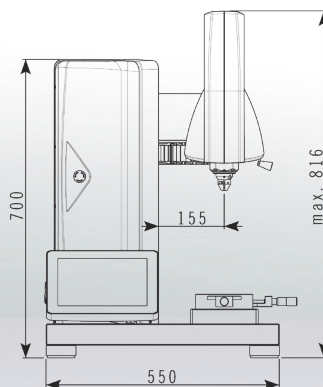

Technical data – DuraScan 50 G5, 70 G5 and 80 G5



FULLY AUTOMATIC

DuraScan 50 G5

Methods and load range	
Load range 0.098 - 612.9 N (0.01 - 62.5 kg) - electronically controlled	•
Load range 0.002452 - 612.9 N (0.00025 - 62.5 kg) - electronically controlled	optional (per indenter)
Vickers (ISO 6507, ASTM E384, E92)	•
Knoop (ISO 4545, ASTM E384, E92)	•
Brinell (ISO 6506, ASTM E10)	•
Equipment	
Fully automated linear tables for positioning of the specimens	•
ecos™ III operating software (for Windows 7, Windows 8, Windows 10)	•
ecos Workflow Pro operating software (for Windows 7, Windows 8, Windows 10)	•
Control via interfaced PC system	•
Automatic test cycle with brightness control and evaluation	•
3-step zoom	•
12 Mpix evaluation camera with CMOS sensor	•
Baseplate of polished granite	•
Legs with integrated damping elements	•
Machine control via integrated PLC	•
Motorised height adjustment of the test unit with rapid traverse	•
Automatic 6x measuring turret	•
12 Mpix overview colour camera (field of view 65 x 50 mm) with active LED coaxial lighting	-
Test table (W x D)	150 x 200 mm
Travelling distance of the axes (X / Y)	150 x 150 mm
Glass scales for X-Y axes to increase the absolute positioning accuracy to < 1 µm	optional
Brinell SmartLight	optional
Software functions	
Template mode	•
CHD, NHD, SHD and serial measurements	•
ecos xCHANGE (XML-based interface for data links)	•
Calibration assistant	•
Multiple specimen module for testing several specimens in one work cycle	•
Integrated TeamViewer client	•
User Rights Management	•
ecos Panorama	optional
ecos AUTOROW	optional
ecos LINEplus	optional
ecos areaMASTER	optional
Interfaces	
Interfaces for PC connection	1 x USB 3.0, 1 x RJ45



DuraScan 70 G5



DuraScan 80 G5

•	•
optional (per indenter)	optional (per indenter)
•	•
•	•
•	•
•	•
•	•
•	•
•	•
•	•
•	•
•	•
•	•
•	•
•	•
•	•
•	•
•	•
150 x 200 mm	150 x 300 mm
150 x 150 mm	300 x 150 mm
optional	optional
optional	optional
•	•
•	•
•	•
•	•
•	•
•	•
•	•
•	•
•	•
•	•
optional	optional
optional	optional
optional	optional
1 x USB 3.0, 1 x RJ45	1 x USB 3.0, 1 x RJ45

Functional dimensions:

Space requirement (W x D) DuraScan 50 G5/70 G5	700 x 600 (mm)
Space requirement (W x D) DuraScan 80 G5	850 x 600 (mm)
Max. workpiece weight	50 kg
Positioning accuracy	± 0.0035 mm
Positioning accuracy with glass scale	< 0.25 µm
Test force application resolution	24 bit
Max. test height	260 mm
Z-axis resolution	2.6 nm
Max. speed on Z-axis	1.2 mm/sec. to 20 mm/sec.

Machine data:

Weight of basic unit (DuraScan 50 G5/ 70 G5)	87 kg
Weight of basic unit (DuraScan 80 G5)	98 kg
Measurements (W x H x D) DuraScan 50 G5/70G5	550 x 700 x 450 (mm)
Measurements (W x H x D) DuraScan 80 G5	700 x 700 x 450 (mm)
Protection class to EN 60529	IP20
Power consumption (max./standby)	120 W/50 W
Max. voltage fluctuations	± 10%
Main fuse (110/230V)	T6,3A
Room temperature (to ISO/ASTM)	23 (± 5)°C

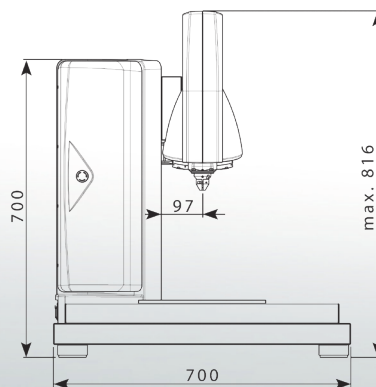

Technical and design modifications as well as printing and typesetting errors reserved. Deviations from the illustrations in colour and form reserved. In some cases the machines/equipment illustrated or described include special options that are available only at additional charge. The equipment scopes and configuration possibilities described in this brochure with respect to the standard equipment and special options for individual machines may differ from country to country. Please check out the standard equipment and special options available in your country with your local EMCO-TEST dealer in advance. Please note at all times: The systems function only within the system limits and support the customer in hardness testing. The responsibility for compliance with national standards and laws remains with the operator of the hardness testing machine.

Benefit from our worldwide sales and service network!

You can find a partner near you on our website www.zwickroell.com.



Find out more at zwickroell.com

Zwick / Roell

EMCO-TEST

EMCO-TEST Prüfmaschinen GmbH

Kellau 174

5431 Kuchl-Salzburg/Austria

office@emcotest.com

www.zwickroell.com/haerte

Tel. +43 6244 204 38

Fax +43 6244 204 38-8

